



**TRANSFORMER BOBBIN
INDUSTRIAL CO.,LTD.**

Tel : 86-769-88789999 Fax : 86-769-88789989
http:// tbi-tw.com e-mail : tb6688@ms46.hinet.net

REVISIONS

REV	SYM	DRAFTER	CHECKER	DATE
①		X.X.YUAN	G.F.YANG	09/22/15
②				
③				

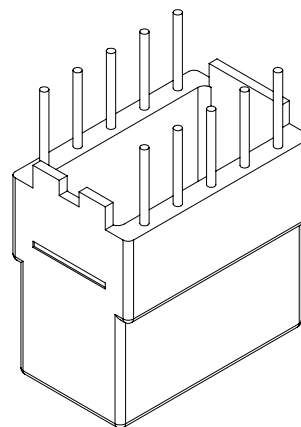
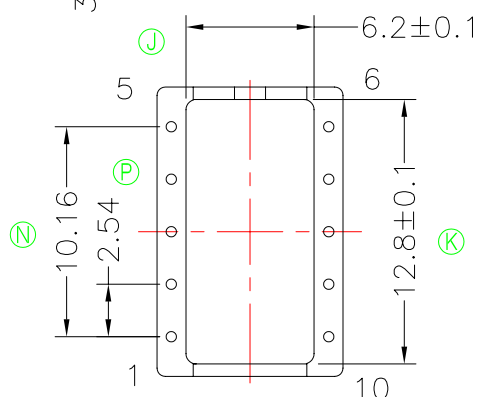
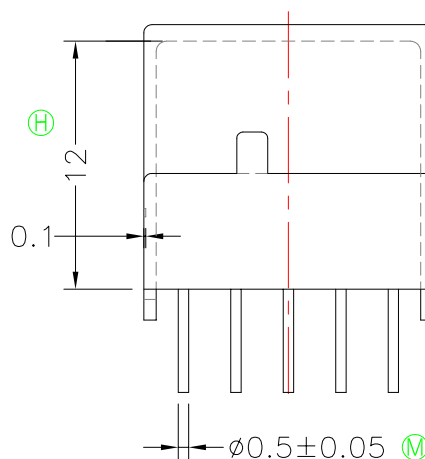
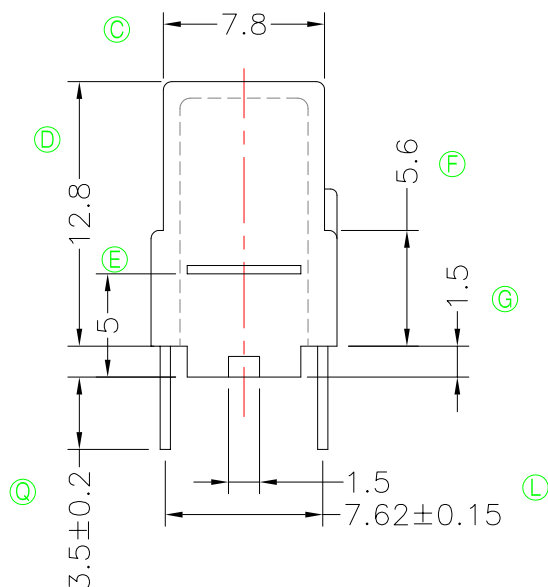
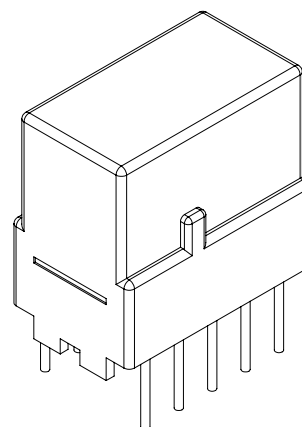
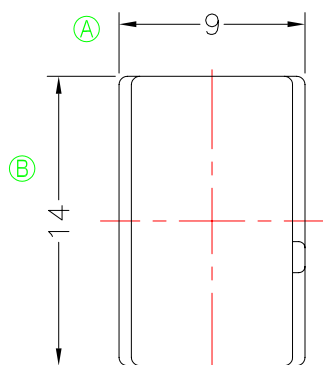

NOTE: 拉力要求 1.0Kg MIN ;

DWG NO.	H1409-10P-TH-2.54-B-11				
PART NO.	MATERIAL (BOBBIN)	MATERIAL (TERMINAL)	TERMINAL (PLATING)	PIN ALLOCATION	NOTE
TBI-218-12021.1106	PM-9630	CP WIRE	Sn	ALL PIN	S
TBI-218-12021.1116	PM-9630	CP WIRE	Sn	CUT PIN #3,4,7,8	H
TBI-218-12021.1126	PM-9630	CP WIRE	Sn	CUT PIN #3,7,9	53GH1409TH01
	TOLERANCE: 0<L<=4:±0.1 4<L<=16:±0.2 16<L<=63:±0.3			UNIT : m / m	SCALE 1 : 1

Finish: 1. PB wire Immersion Sn on terminal : Thickness:Sn plating,100%,5 μm (200 μ inches) min,Base nickel 0.625 μm (25 μ inches) min.
2. CP wire Immersion Sn on terminal : Thickness:Sn plating,100%,5 μm (200 μ inches) min.
3. Coplanarity deviation: 0.10 mm (0.004 inches)max.

REV	1
-----	---