



TRANSFORMER BOBBIN  
INDUSTRIAL CO., LTD.

Tel : 86-769-88789999 Fax : 86-769-88789989  
http://tbi-tw.com e-mail : tb6688@ms46.hinet.net

REVISIONS

REV	SYM	DRAFTER	CHECKER	DATE
1		X.X.YUAN	G.F.YANG	04/04/11
2				
3				

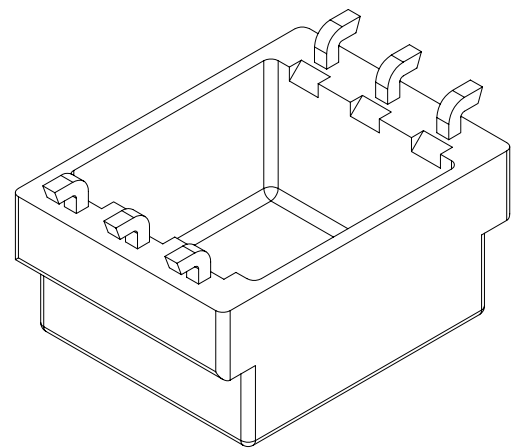
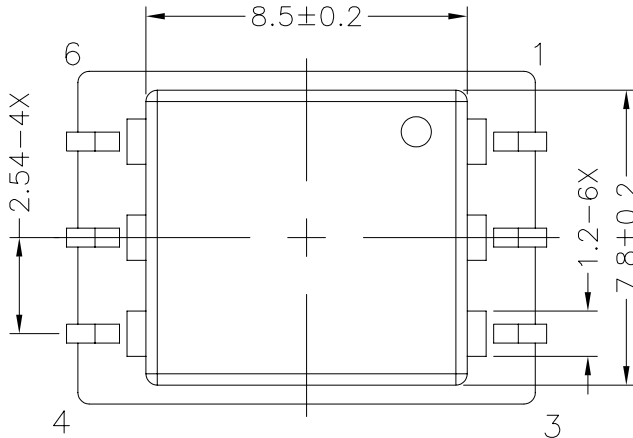
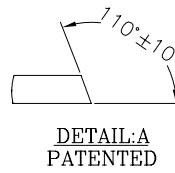
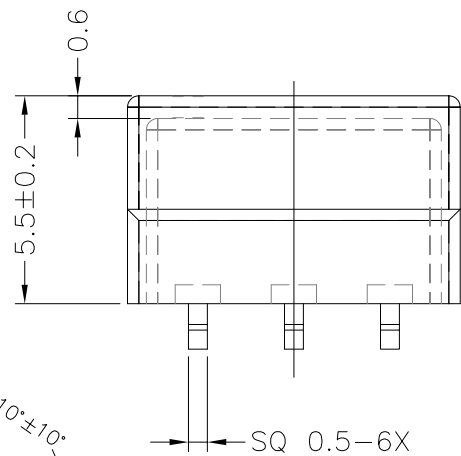
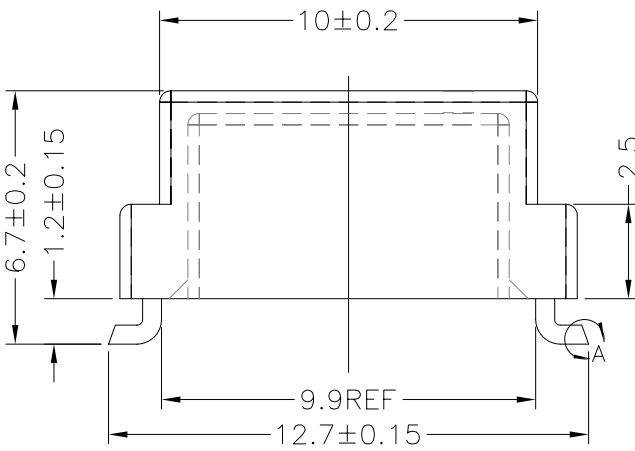
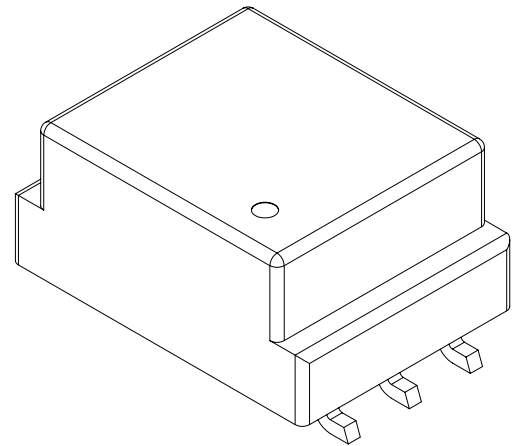
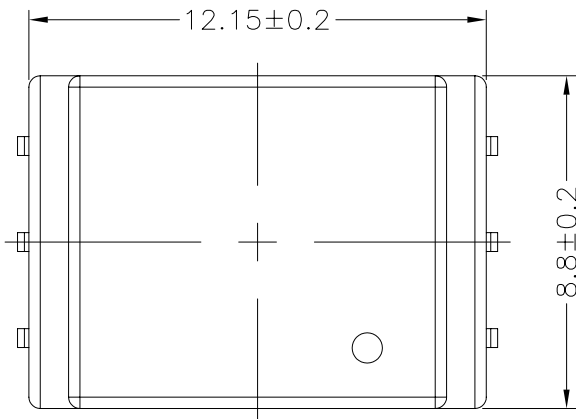

DWG NO.	H12X8-6P-L-2.54-B-1				
PART NO.	MATERIAL (BOBBIN)	MATERIAL (TERMINAL)	TERMINAL (PLATING)	PIN ALLOCATION	NOTE
TBI-113-44061.103	PM-9630JT	P.B	Sn	ALL PIN	53GEGH6PL001   S
					H

	TOLERANCE:	.X±0.15	.XX±0.10	.XXX±0.05	UNIT : m/m	SCALE	5 : 1
	Finish:	1. PB wire Immersion Sn on terminal : Thickness:Sn plating,100,5 μm (200 μ inches) min,Base nickel 0.625 μm (25 μ inches) min. 2. CP wire Immersion Sn on terminal : Thickness:Sn plating,100,5 μm (200 μ inches) min. 3. Coplanarity deviation: 0.10 mm (0.004 inches) max.				REV	1