

TBI TRANSFORMER BOBBIN INDUSTRIAL CO., LTD.

Phone 886-2-22929999 Fax 886-2-22925236
E-MAIL: tb6688@ms46.hinet.net

REVISIONS

REV	SYM	DRAFTER	CHECKER	DATE
△		T.S.LII	W.H.HSU	05/31/04
△				
△				

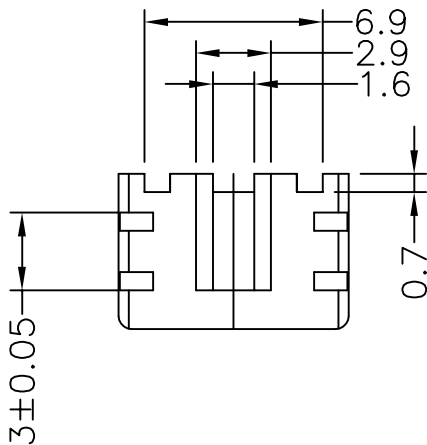
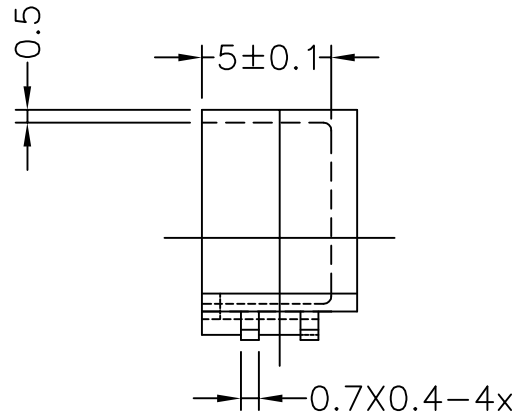
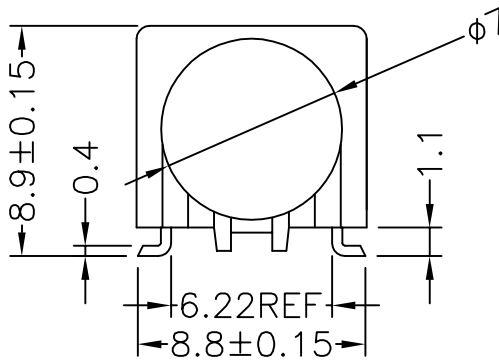
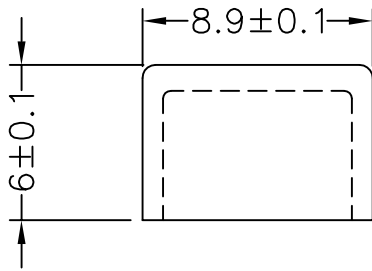

PART NO. T12.5-4P-L-3.0-A-2

DWG NO. TBI-113-27011.2XX

TBI NO. MATERIAL (BOBBIN) MATERIAL (TERMINAL) TERMINAL (PLATING)

113-27011.203 DAP AM-113 P.B Sn

.203

ALL PIN

PART NO.

REV

MODE NO

PIN LOCATION

Finish:

- 1-1. Immersion gold on terminal.
Thickness gold 0.075 μm (3 μ inches) min,
Base nickel 0.625 μm (25 μ inches) min.
Immersion Sn on terminal.
- 1-2. Terminal: Sn plating, 100, 5 μm (200 μ inches) min
Base nickel 0.625 μm (25 μ inches) min.
- 1-3. Immersion Sn/Pb on terminal.
Terminal: Sn/Pb plating, 90/10, 5 μm (200 μ inches) min
Base nickel 0.625 μm (25 μ inches) min. (for pin GW type)
2. Coplanarity deviation: 0.004 inches max.

TOLERANCE

.X ±0.15
.XX ±0.10
.XXX ±0.05

UNIT

m/m

SCALE

3.5 : 1

REV

1