



TRANSFORMER BOBBIN
INDUSTRIAL CO.,LTD.

Tel : 86-769-88789999 Fax : 86-769-88789989
http:// tbi-tw.com e-mail : tb6688@ms46.hinet.net

REVISIONS

REV	SYM	DRAFTER	CHECKER	DATE
2		T.S.LII	W.H.HSU	07/24/06
3		T.S.LII	W.H.HSU	04/02/07
4		S.Y.TANG	W.H.HSU	04/02/07

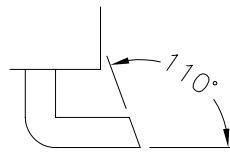
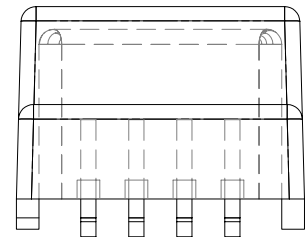
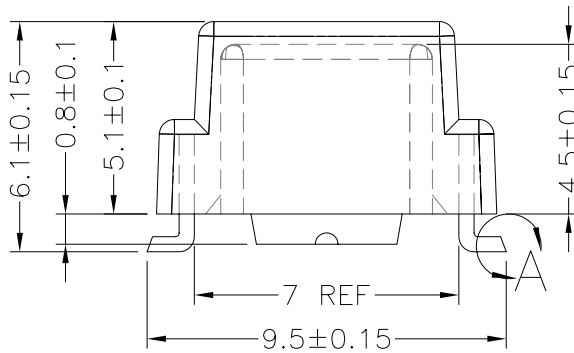
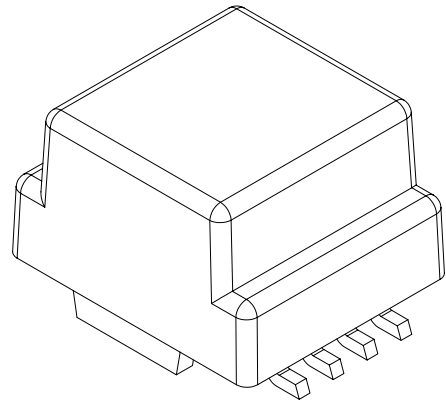
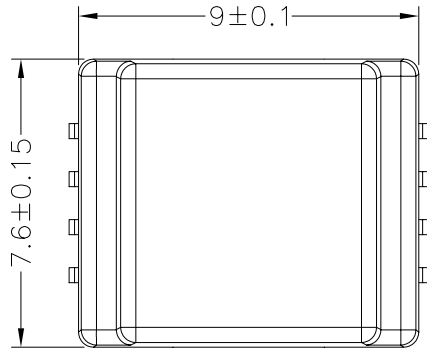

DETAIL : A
(PATENTED)

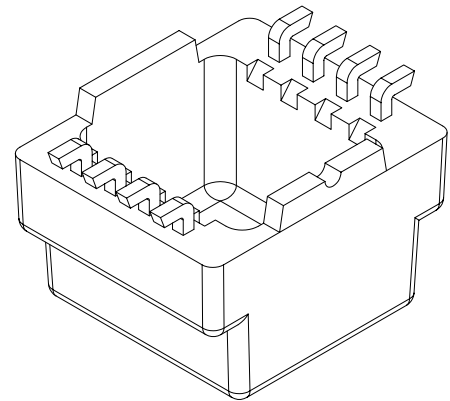
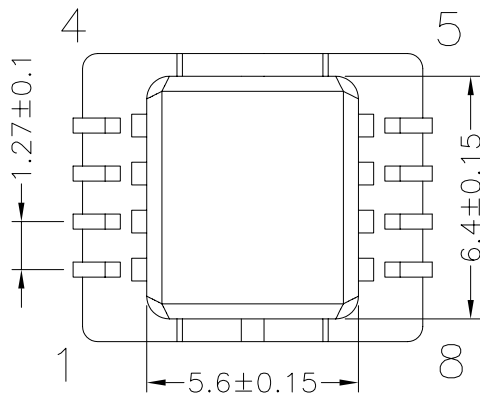

DWG NO. C0009-8P-L-1.27-A-2

PART NO.	MATERIAL (BOBBIN)	MATERIAL (TERMINAL)	TERMINAL (PLATING)	PIN ALLOCATION	NOTE
TBI-113-23011.203	AM-113	P.B	Sn	ALL PIN	
TBI-113-23011.213	AM-113	P.B	Sn	PIN CUT:NO.2,3,6,7	

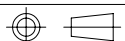

TOLERANCE: .X±0.15 .XX±0.10 .XXX±0.05

UNIT : m / m

SCALE 5 : 1

Finish: 1. Pb wire Immersion Sn on terminal : Thickness:Sn plating,100,5 μm (200 μ inches) min,Base nickel 0.625 μm (25 μ inches) min.
2. CP wire Immersion Sn on terminal : Thickness:Sn plating,100,5 μm (200 μ inches) min.
3. Coplanarity deviation: 0.10 mm (0.004 inches) max.

REV 4