



**TRANSFORMER BOBBIN  
INDUSTRIAL CO.,LTD.**

Tel : 86-769-88789999 Fax : 86-769-88789989  
http:// tbi-tw.com e-mail : tb6688@ms46.hinet.net

**REVISIONS**

REV	SYM	DRAFTER	CHECKER	DATE
1		F.LU	G.F.YANG	02/27/13
2				
3				

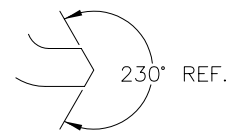
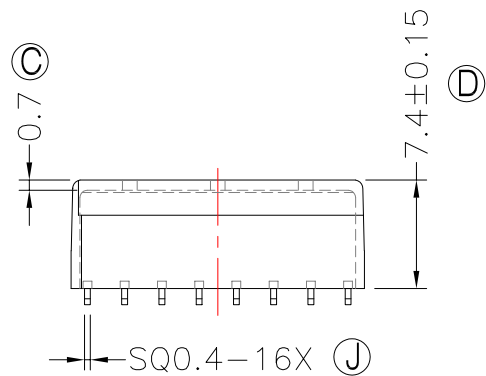
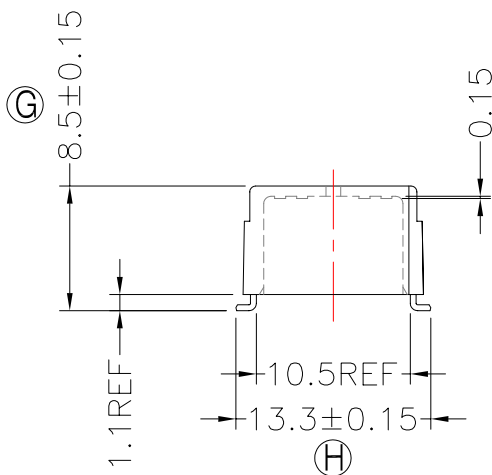
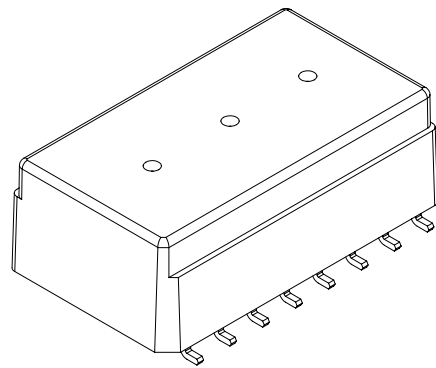
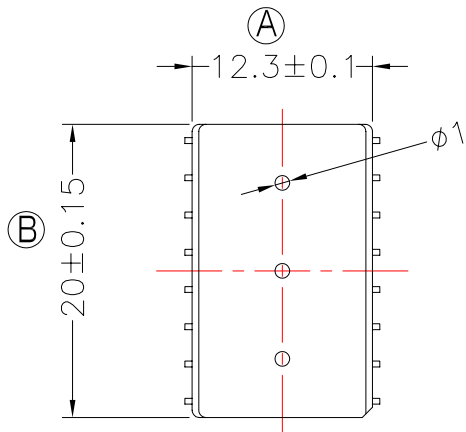

**DETAIL:A  
PATENTED**

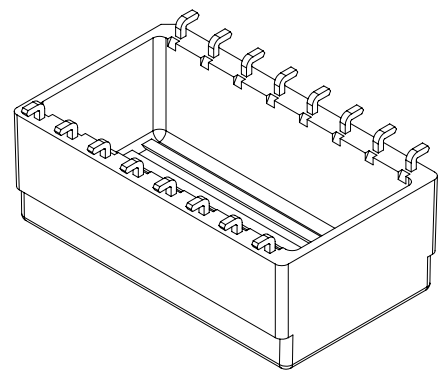
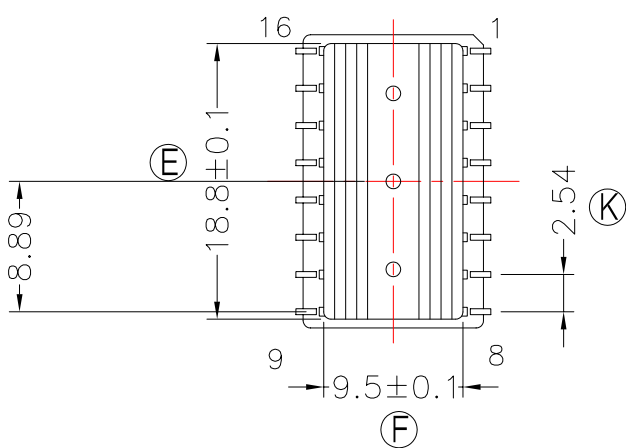

NOTE:CASE 頂部共面度為0.10 MAX.

DWG NO.	K30SS-16P-L-2.54-A5-11				
PART NO.	MATERIAL (BOBBIN)	MATERIAL (TERMINAL)	TERMINAL (PLATING)	PIN ALLOCATION	NOTE
TBI-113-17151.1103	PM-9630	P.B C5191	Sn	ALL PIN	S
TOLERANCE: 0<L<=4:±0.1 4<L<=16:±0.2 16<L<=63:±0.3 UNIT : m / m				SCALE 1 : 1	

**Finish:** 1. PB wire Immersion Sn on terminal : Thickness:Sn plating,100,5 μm (200 μ inches) min,Base nickel 0.625 μm (25 μ inches) min.  
2. CP wire Immersion Sn on terminal : Thickness:Sn plating,100,5 μm (200 μ inches) min.  
3. Coplanarity deviation: 0.10 mm (0.004 inches)max.

REV 1