



TRANSFORMER BOBBIN  
INDUSTRIAL CO., LTD.

Tel : 86-769-88789999 Fax : 86-769-88789989  
http:// tbi-tw.com e-mail : tb6688@ms46.hinet.net

REVISIONS

REV	SYM	DRAFTER	CHECKER	DATE
3		S.M.SHIH	S.M.SHIH	04/02/07
4		X.H.GU	G.F.YANG	10/23/08
5		X.H.GU	G.F.YANG	09/30/09

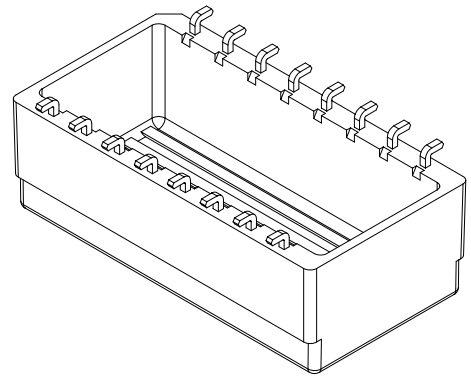
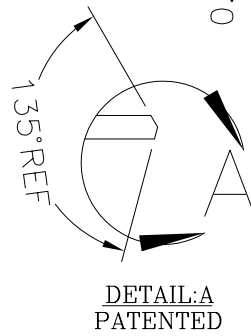
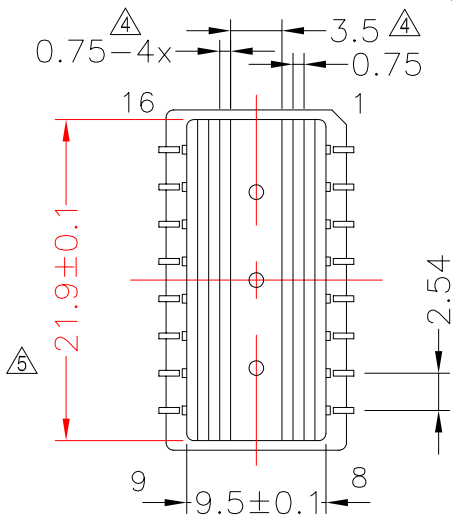
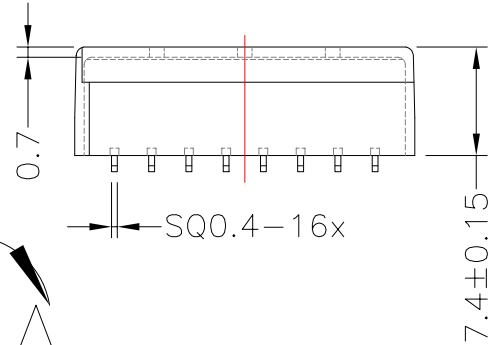
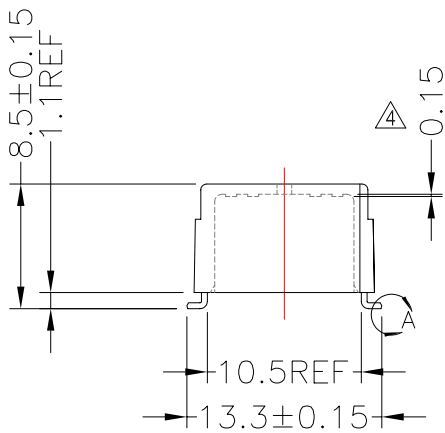
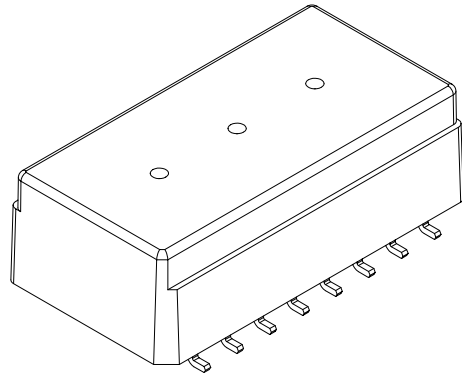
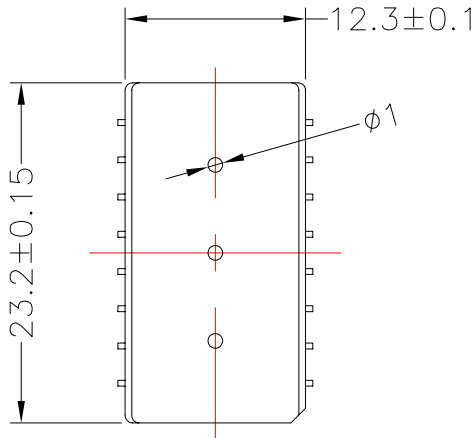

NOTE: CASE 頂部共面度為0.10 MAX.

DWG NO. K30SS-16P-L-2.54-B-1

PART NO.	MATERIAL (BOBBIN)	MATERIAL (TERMINAL)	TERMINAL (PLATING)	PIN ALLOCATION	NOTE
TBI-113-17021.103	PM-9630	P.B C5191	Sn	ALL PIN	54GTR562

TOLERANCE : .X ±0.15 .XX ±0.10 .XXX ±0.05 UNIT : m / mm SCALE 2 : 1

Finish: 1. PB wire Immersion Sn on terminal : Thickness:Sn plating,100,5 μm (200 μ inches) min,Base nickel 0.625 μm (25 μ inches) min.  
2. CP wire Immersion Sn on terminal : Thickness:Sn plating,100,5 μm (200 μ inches) min.  
3. Coplanarity deviation: 0.10 mm (0.004 inches) max.

REV 5