

REVISIONS				
REV	SYM	DRAFTER	CHECKER	DATE
1		X.H.GU	G.F.YANG	10/25/11
2				
3				

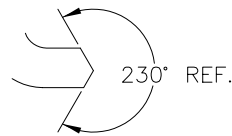

DETAIL:A  
PATENTED

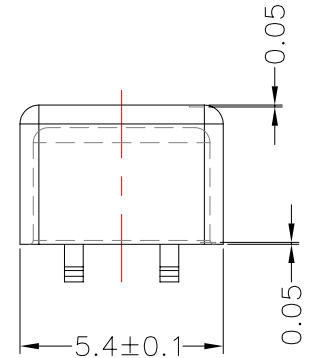
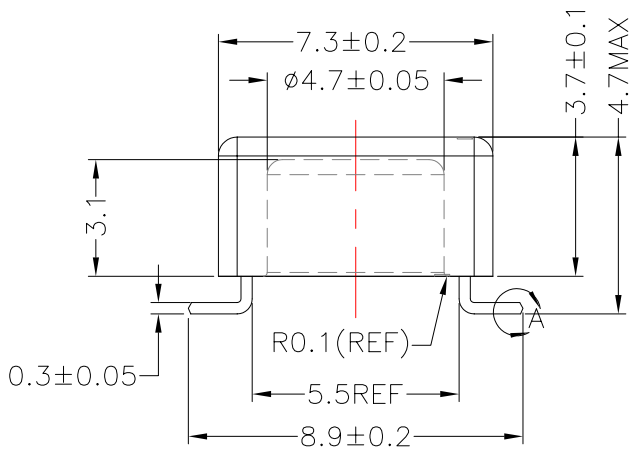
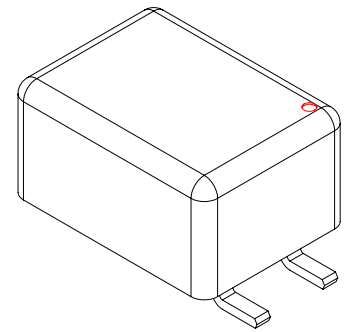
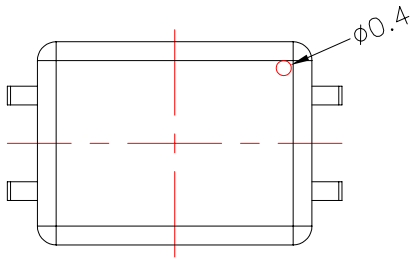
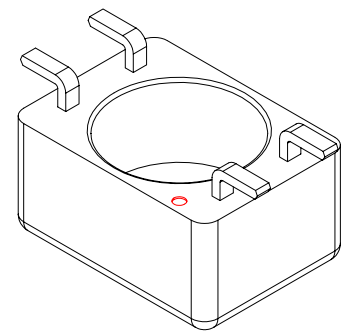
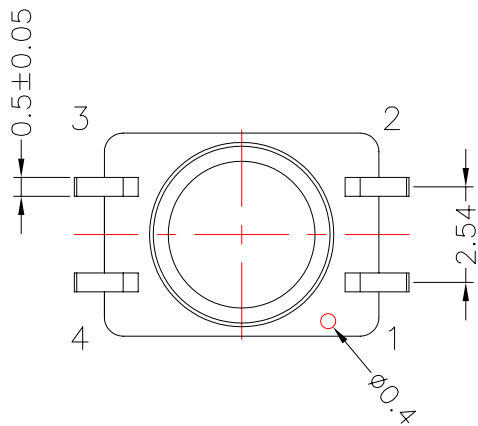

NOTE: CASE 頂部共面度為0.1 MAX.

DWG NO.	K5-4P-L-2.54-D-11				
PART NO.	MATERIAL (BOBBIN)	MATERIAL (TERMINAL)	TERMINAL (PLATING)	PIN ALLOCATION	NOTE
TBI-113-12041.1103	PM-9630	PB	Sn	ALL PIN	
					H
<p>TOLERANCE: .X±0.15 .XX±0.10 .XXX±0.05      UNIT : m / m      SCALE 5 : 1</p>					
<p>Finish: 1. PB wire Immersion Sn on terminal : Thickness:Sn plating,100,5 μ m (200 μ inches) min,Base nickel 0.625 μ m (25 μ inches) min.                  2. CP wire Immersion Sn on terminal : Thickness:Sn plating,100,5 μ m (200 μ inches) min.                  3. Coplanarity deviation: 0.08 mm (0.003 inches)max.</p>					
	REV	1			