



TRANSFORMER BOBBIN INDUSTRIAL CO.,LTD.

Tel : 86-769-88789999 Fax : 86-769-88789989  
 http:// tbi-tw.com e-mail : tb6688@ms46.hinet.net

REVISIONS

REV	SYM	DRAFTER	CHECKER	DATE
1		X.X.YUAN	G.F.YANG	04/05/16
2				
3				

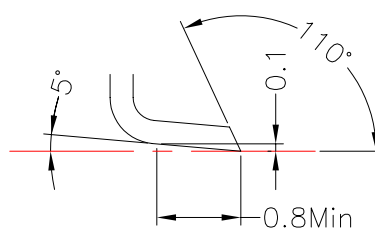
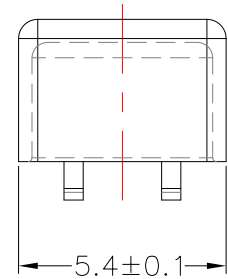
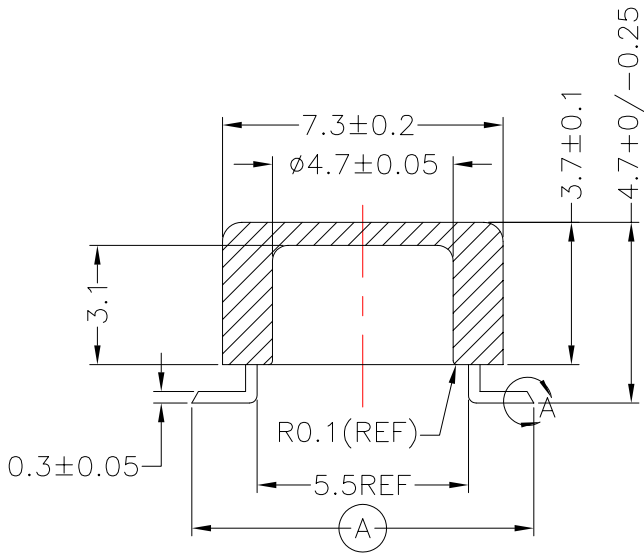
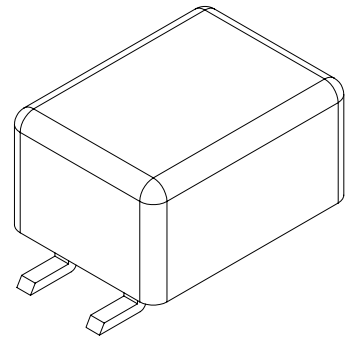
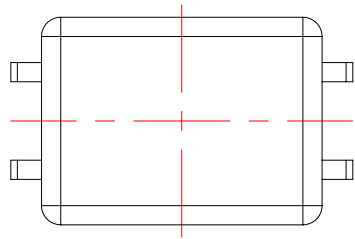

DETAIL:A-10:1  
PATENTED

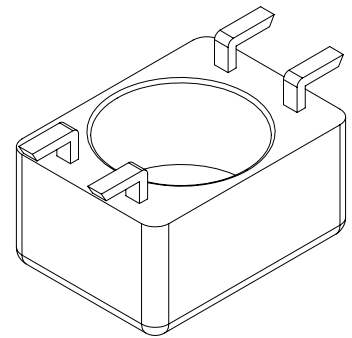
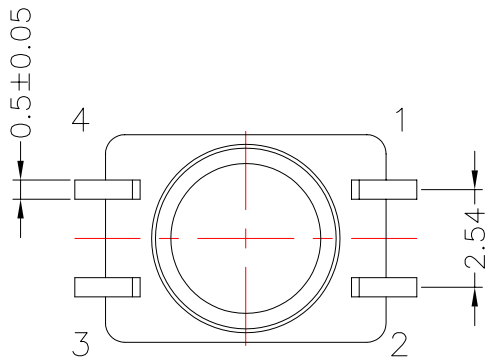

NOTE : 1. 焊前拉力1.0KgMin(焊錫溫度420°C/5S).  
 2. CASE 頂部共面度為0.1 MAX.

DWG NO.	K5-4P-L-2.54-A-22				
PART NO.	MATERIAL (BOBBIN)	MATERIAL (TERMINAL)	TERMINAL (PLATING)	PIN ALLOCATION	NOTE
TBI-113-12011.2203	DAP WH-9100	PB	Sn	ALL PIN (A)=8.9±0.2	H
TBI-113-12011.2213	DAP WH-9100	PB	Sn	ALL PIN (A)=7.5±0.2	
	TOLERANCE: .X±0.15 .XX±0.10 .XXX±0.05			UNIT : m/m	SCALE 5 : 1
Finish: 1. PB wire Immersion Sn on terminal : Thickness:Sn plating,100%,5 μm (200 μ inches) min,Base nickel 0.625 μm (25 μ inches) min. 2. CP wire Immersion Sn on terminal : Thickness:Sn plating,100%,5 μm (200 μ inches) min. 3. Coplanarity deviation: 0.08 mm (0.003 inches) max.					REV 1