



TRANSFORMER BOBBIN INDUSTRIAL CO.,LTD.

Tel : 86-769-88789999 Fax : 86-769-88789989
 http:// tbi-tw.com e-mail : tb6688@ms46.hinet.net

REVISIONS

REV	SYM	DRAFTER	CHECKER	DATE
①		YAN.TANG	G.F.YANG	07/29/10
②				
③				

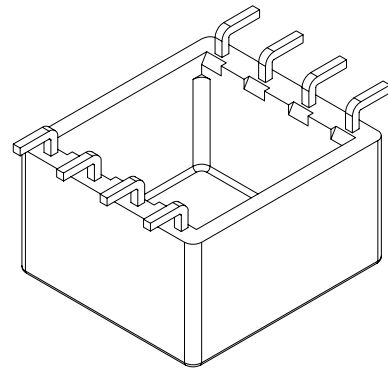
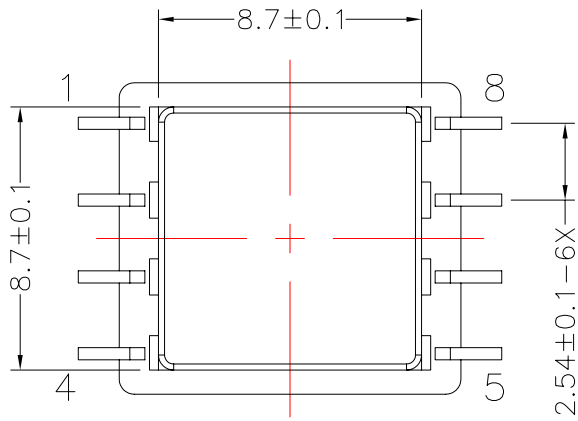
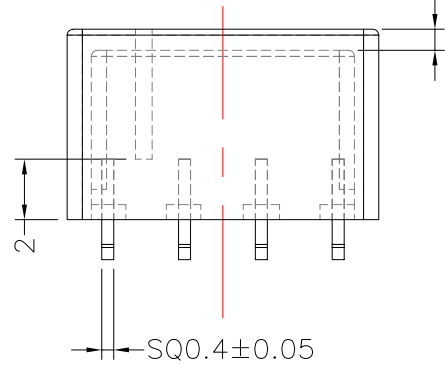
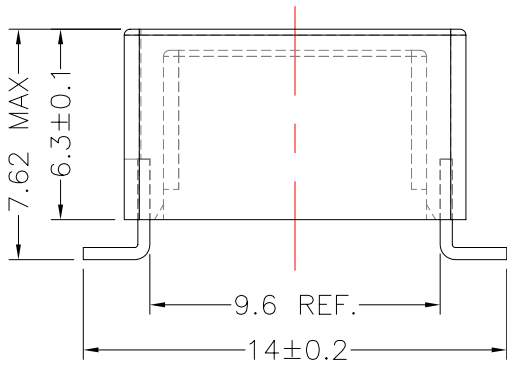
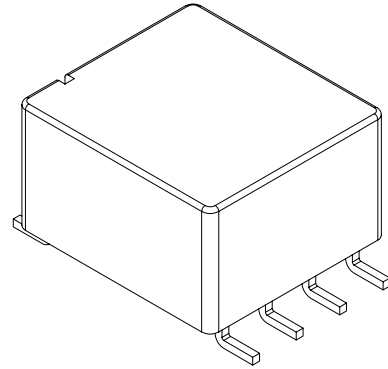
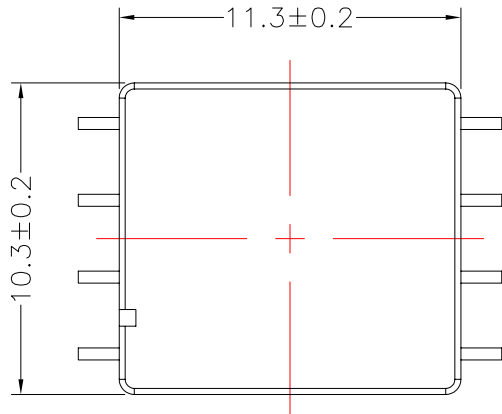

NOTE: Pull Strenght 1.0kg (min)

DWG NO.	TR10-8P-L-2.54-B0-11				
PART NO.	MATERIAL (BOBBIN)	MATERIAL (TERMINAL)	TERMINAL (PLATING)	PIN ALLOCATION	NOTE
TBI-113-06201.1103	PM-9630	PB	Sn	ALL PIN	H

	TOLERANCE: .X±0.15 .XX±0.10 .XXX±0.05	UNIT : m / m	SCALE 4 : 1
	Finish: 1. PB wire Immersion Sn on terminal : Thickness:Sn plating,100,5 μ m (200 μ inches) min,Base nickel 0.625 μ m (25 μ inches) min. 2. CP wire Immersion Sn on terminal : Thickness:Sn plating,100,5 μ m (200 μ inches) min. 3. Coplanarity deviation: 0.10 mm (0.004 inches) max.	REV	1