

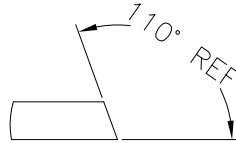

TRANSFORMER BOBBIN INDUSTRIAL CO.,LTD.

Tel : 86-769-88789999 Fax : 86-769-88789989  
 http:// tbi-tw.com e-mail : tb6688@ms46.hinet.net

REVISIONS				
REV	SYM	DRAFTER	CHECKER	DATE
①		YAN.TANG	G.F.YANG	11/16/07
②				
③				

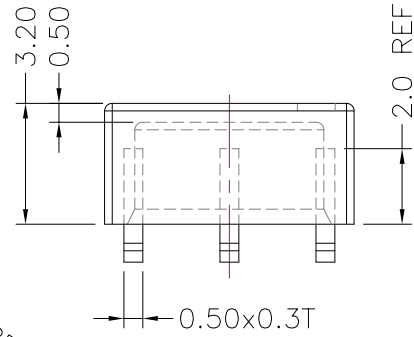
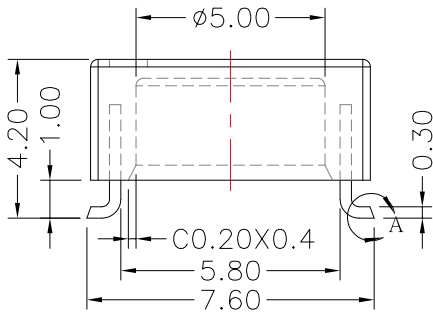
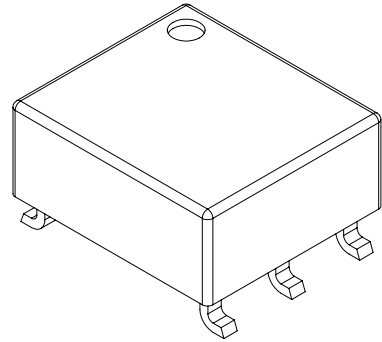
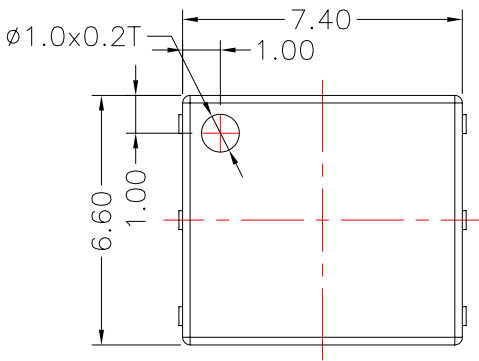

DETAIL:A  
PATENTED

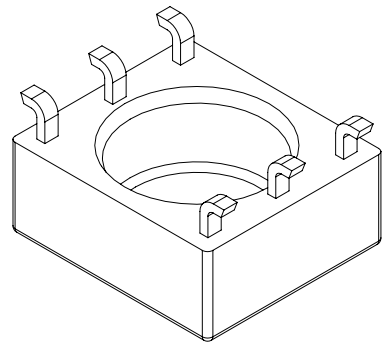
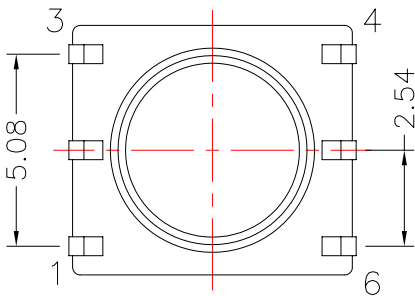

Note:pin tension load:0.8kg min.

DWG NO. H7X6-6P-L-2.54-G-11

PART NO.	MATERIAL (BOBBIN)	MATERIAL (TERMINAL)	TERMINAL (PLATING)	PIN ALLOCATION	NOTE
TBI-113-03071.1103	PM-9630	PB	Sn	ALL PIN	
TBI-113-03071.1113	PM-9630	PB	Sn	CUT PIN #2,5	
TOLERANCE: .X±0.15 .XX±0.10 .XXX±0.05				UNIT : m / m	SCALE 5 : 1
Finish: 1. Pb wire Immersion Sn on terminal : Thickness:Sn plating,100,5 μm (200 μ inches) min,Base nickel 0.625 μm (25 μ inches) min. 2. CP wire Immersion Sn on terminal : Thickness:Sn plating,100,5 μm (200 μ inches) min. 3. Coplanarity deviation: 0.10 mm (0.004 inches) max.					REV 1