

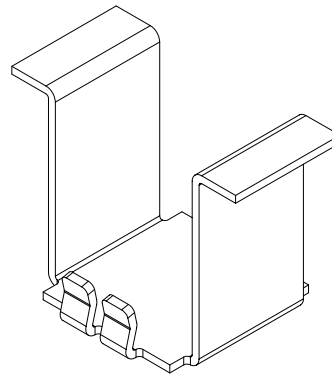

**TRANSFORMER BOBBIN  
INDUSTRIAL CO.,LTD.**

Tel : 86-769-88789999 Fax : 86-769-88789989  
 http:// tbi-tw.com e-mail : tb6688@ms46.hinet.net

REVISIONS				
REV	SYM	DRAFTER	CHECKER	DATE
①		S.Y.TANG	G.F.YANG	12/11/07
②				
③				

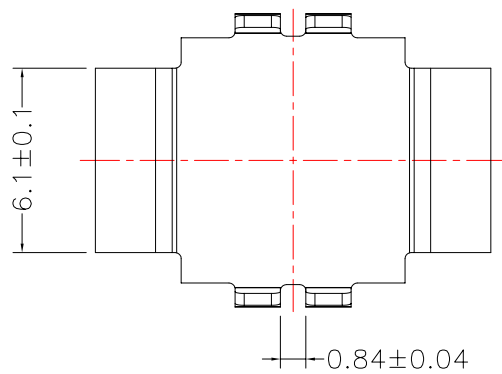
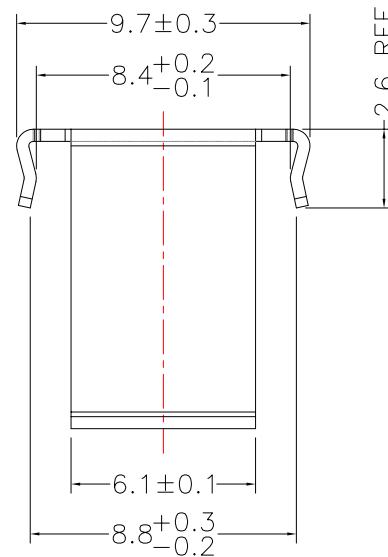
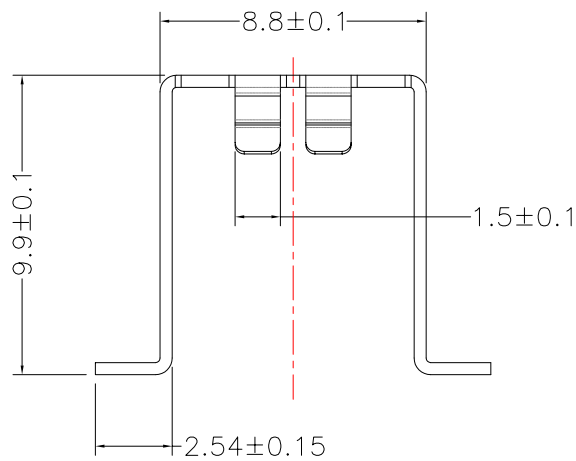
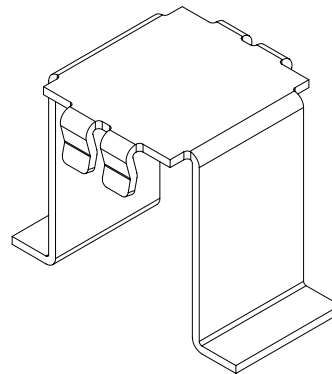
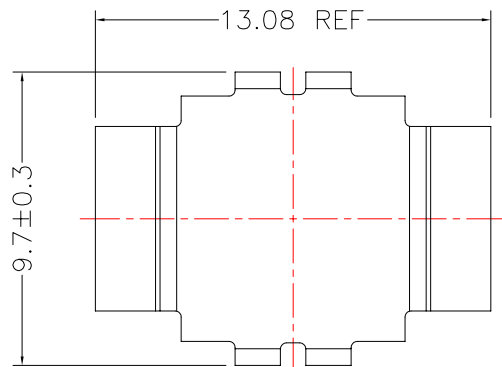

T=0.4

DWG NO.	EF12.6-CLIP				
PART NO.	MATERIAL (BOBBIN)	MATERIAL (CLIP)	TERMINAL (PLATING)	PIN ALLOCATION	NOTE
TBI-410-02011.1		C1100	Sn		
TOLERANCE: .X±0.15 .XX±0.10 .XXX±0.05					
				UNIT : m / m	SCALE 4 : 1

Finish: 1. Copper Immersion Sn on terminal : Thickness:Sn plating,100,5 μm (200 μ inches) min,Base nickel 0.625 μm (25 μ inches) min.  
 2. CP wire Immersion Sn on terminal : Thickness:Sn plating,100,5 μm (200 μ inches) min.  
 3. Coplanarity deviation: 0.10 mm (0.004 inches) max.

REV	1
-----	---