

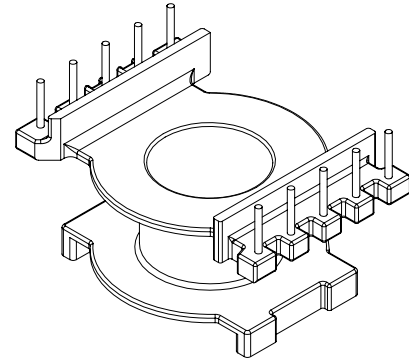

**TRANSFORMER BOBBIN  
INDUSTRIAL CO.,LTD.**

Tel : 86-769-88789999 Fax : 86-769-88789989  
http:// tbi-tw.com e-mail : tb6688@ms46.hinet.net

REVISIONS				
REV	SYM	DRAFTER	CHECKER	DATE
△2		M.WANG	G.F.YANG	09/14/16
△3				
△4				

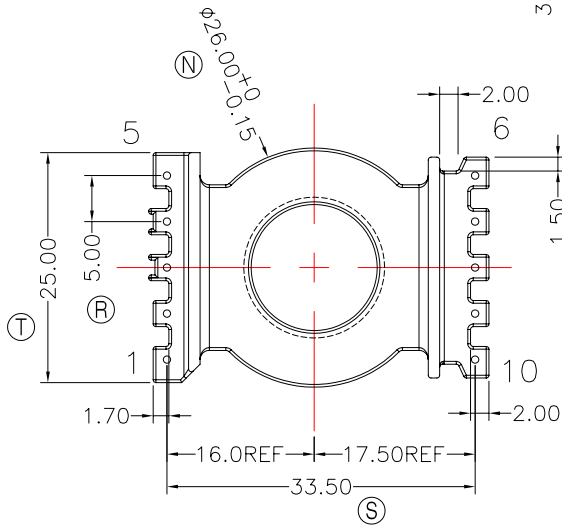
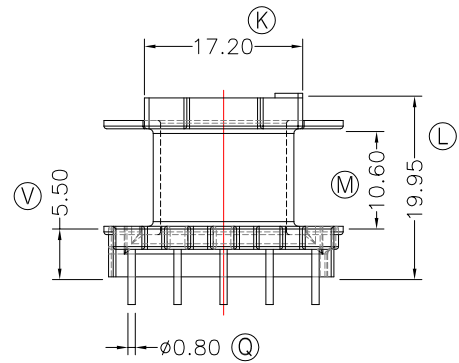
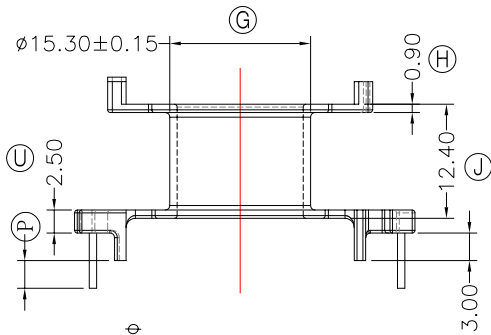
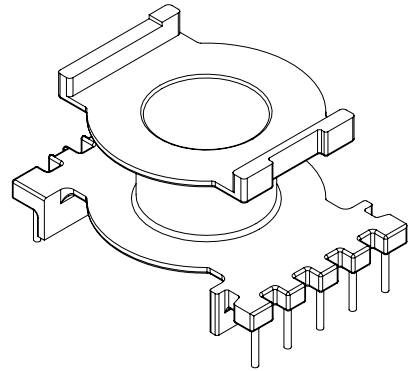
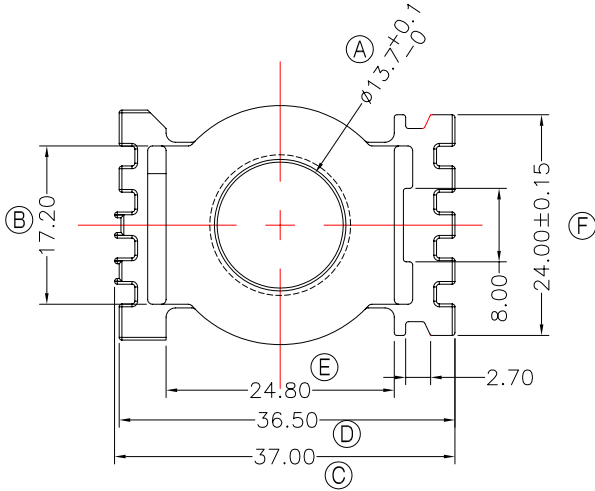

- NOTE:
- 1.WINDING SPACE: 5.25mm\*10.6mm=55.65 mm<sup>3</sup>
  - 2.焊錫前拉力:1.5KG MIN,焊錫後拉力:2.0KG MIN;
  - 3.任意一點強度須2.0kg MIN;

DWG NO.	CC3319-10P-TH-5.0-B5-17				
PART NO.	MATERIAL (BOBBIN)	MATERIAL (TERMINAL)	TERMINAL (PLATING)	PIN ALLOCATION	NOTE
TBI-239-04251.1706	PM-9823	CP WIRE	Sn	ALL PIN (P) =3±0.2	S
					H

TOLERANCE: 0<L<=4:±0.1 4<L<=16:±0.2 16<L<=63:±0.3 UNIT : m / m SCALE 1 : 1

Finish: 1. PB wire Immersion Sn on terminal : Thickness:Sn plating,100,5 μm (200 μ inches) min,Base nickel 0.625 μm (25 μ inches) min.  
2. CP wire Immersion Sn on terminal : Thickness:Sn plating,100,5 μm (200 μ inches) min.  
3. Coplanarity deviation: 0.10 mm (0.004 inches) max.

REV	1
-----	---