



TRANSFORMER BOBBIN INDUSTRIAL CO.,LTD.

Tel : 86-769-88789999 Fax : 86-769-88789989
 http:// tbi-tw.com e-mail : tb6688@ms46.hinet.net

REVISIONS

REV	SYM	DRAFTER	CHECKER	DATE
①		X.X.YUAN	G.F.YANG	08/01/12
②				
③				

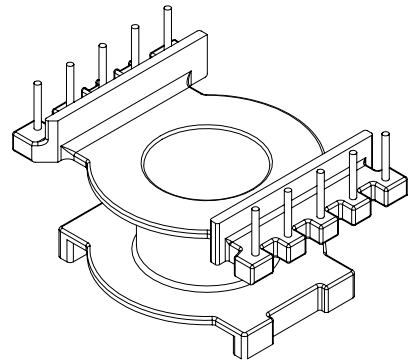
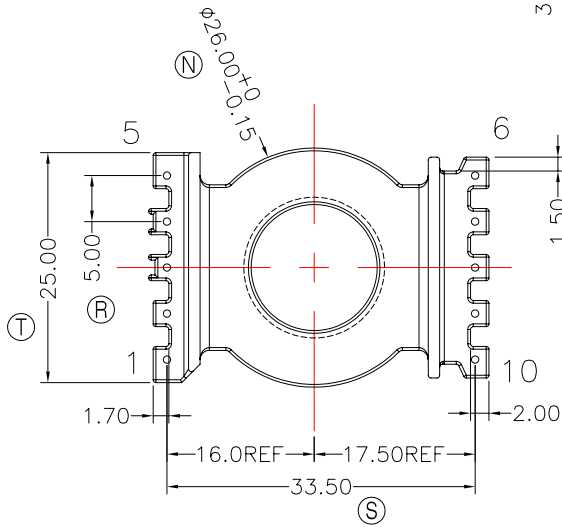
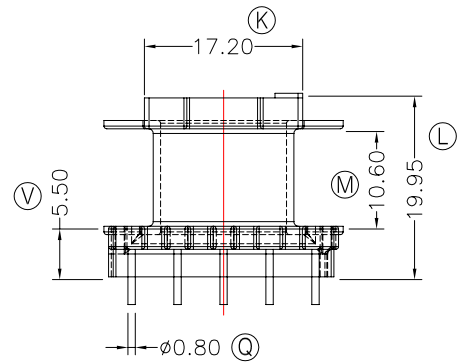
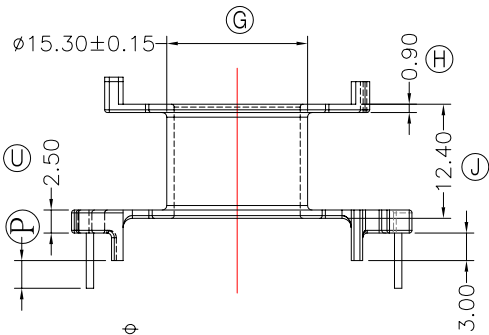
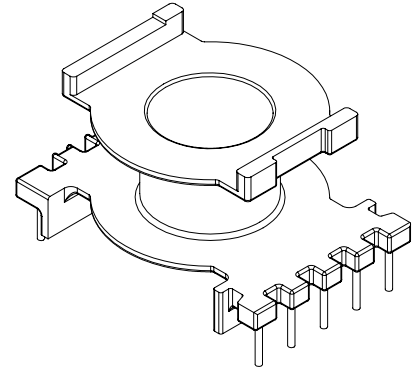
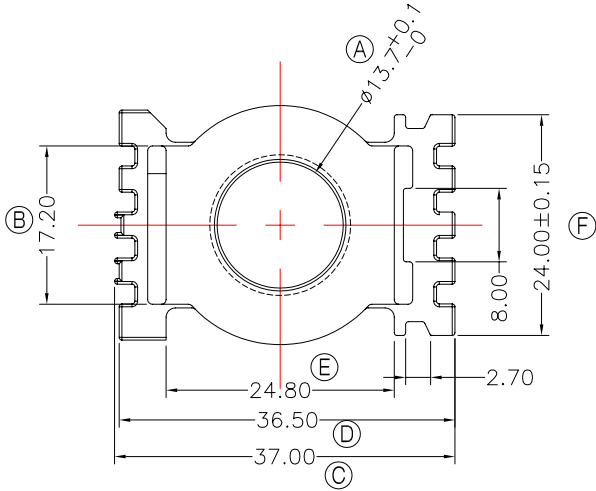

- 1.WINDING SPACE: 5.25mm*10.6mm=55.65 mm³
- 2.焊錫前拉力:1.5KG MIN,焊錫後拉力:2.0KG MIN;
- 3.任意一點強度須2.0kg MIN;

DWG NO.	CC3319-10P-TH-5.0-B5-11				
PART NO.	MATERIAL (BOBBIN)	MATERIAL (TERMINAL)	TERMINAL (PLATING)	PIN ALLOCATION	NOTE
TBI-239-04251.1106	PM-9630	CP WIRE	Sn	ALL PIN (P)=3±0.2	S
TBI-239-04251.1116	PM-9630	CP WIRE	Sn	CUT PIN #6.7.8.9.10 (P)=2.75±0.2	H
TBI-239-04251.1126	PM-9630	CP WIRE	Sn	ALL PIN (P)=4±0.2	

TOLERANCE: 0<L<=4:±0.1 4<L<=16:±0.2 16<L<=63:±0.3 UNIT : m / m SCALE 1 : 1

Finish: 1. PB wire Immersion Sn on terminal : Thickness:Sn plating,100,5 μm (200 μ inches) min,Base nickel 0.625 μm (25 μ inches) min.
 2. CP wire Immersion Sn on terminal : Thickness:Sn plating,100,5 μm (200 μ inches) min.
 3. Coplanarity deviation: 0.10 mm (0.004 inches) max.

REV	1
-----	---