



TRANSFORMER BOBBIN INDUSTRIAL CO.,LTD.

Tel : 86-769-88789999 Fax : 86-769-88789989
 http:// tbi-tw.com e-mail : tb6688@ms46.hinet.net

REVISIONS

REV	SYM	DRAFTER	CHECKER	DATE
1		X.H.GU	G.F.YANG	04/29/11
2		X.H.GU	G.F.YANG	06/17/11
3		X.H.GU	G.F.YANG	11/07/11

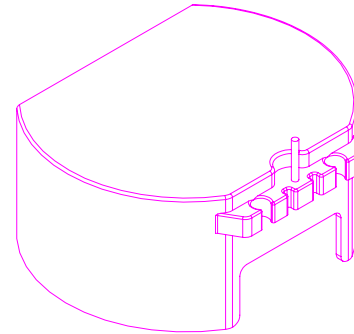
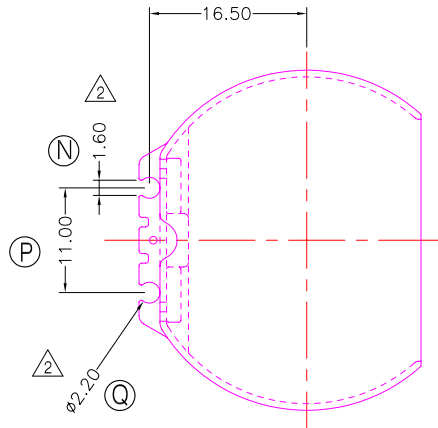
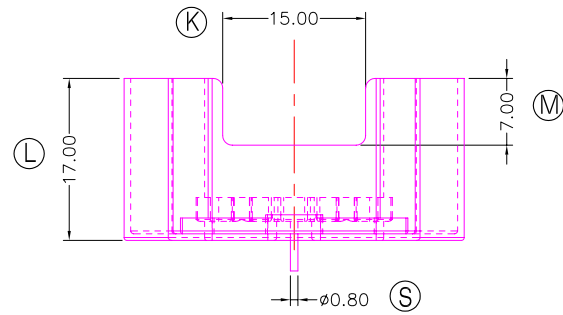
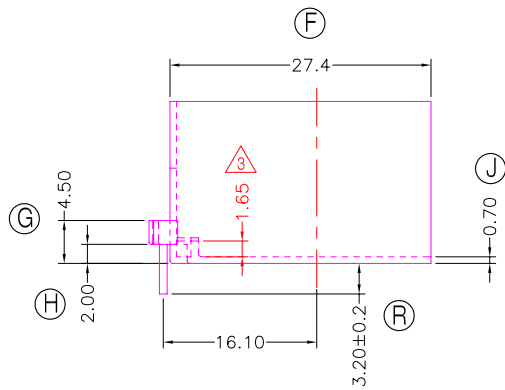
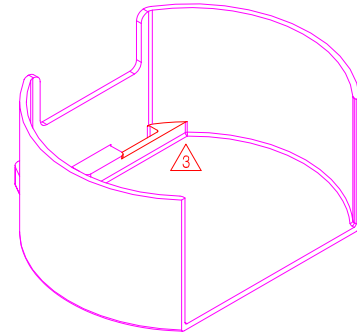
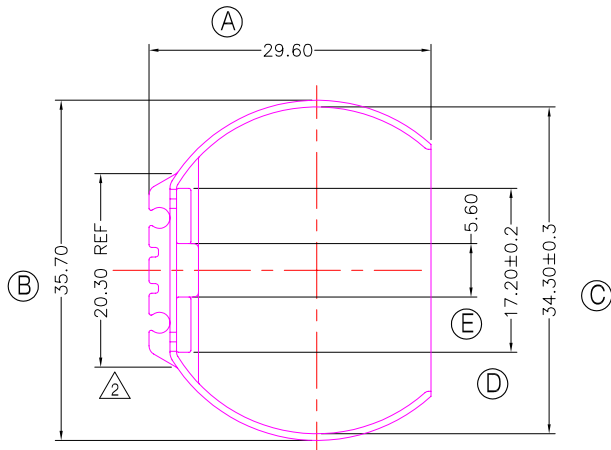

注: 1.任意一點強度須1.0kg MIN;
 2.PIN拉力須焊前1.0Kg MIN焊后1.5Kg MIN.
 與TBI-239-04401.11XX(CC33-17H-5P-TH-5.0-D0-11)配套使用;

DWG NO. CC33-17H-1P-CASE-D1-11 3

PART NO.	MATERIAL (BOBBIN)	MATERIAL (TERMINAL)	TERMINAL (PLATING)	PIN ALLOCATION	NOTE
TBI-239-04411.1106	PM-9630	CP WIRE	Sn	ALL PIN	S
TBI-239-04411.1116	PM-9630	CP WIRE	Sn	NO PIN	H
TOLERANCE: 0<L<=4:±0.1 4<L<=16:±0.2 16<L:±0.3				UNIT : m / m	SCALE 1 : 1

Finish: 1. PB wire Immersion Sn on terminal : Thickness:Sn plating,100,5 μm (200 μ inches) min,Base nickel 0.625 μm (25 μ inches) min.
 2. CP wire Immersion Sn on terminal : Thickness:Sn plating,100,5 μm (200 μ inches) min.
 3. Coplanarity deviation: 0.10 mm (0.004 inches) max.

REV 3