



TRANSFORMER BOBBIN INDUSTRIAL CO.,LTD.

Tel : 86-769-88789999 Fax : 86-769-88789989
http:// tbi-tw.com e-mail : tb6688@ms46.hinet.net

REVISIONS

REV	SYM	DRAFTER	CHECKER	DATE
1		X.H.GU	G.F.YANG	06/11/12
2		X.H.GU	G.F.YANG	10/24/12
3				

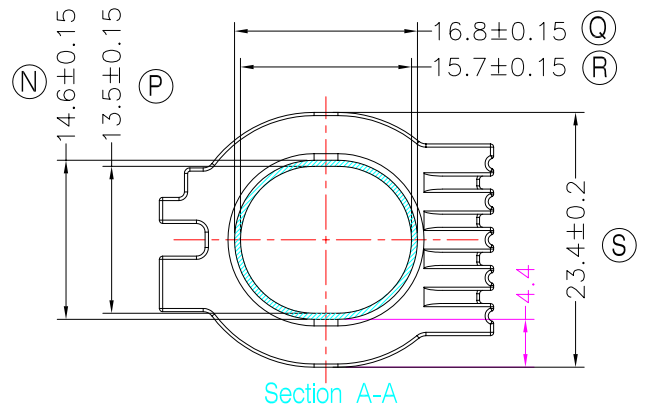
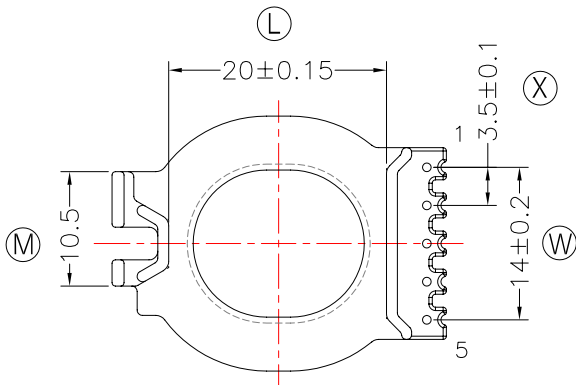
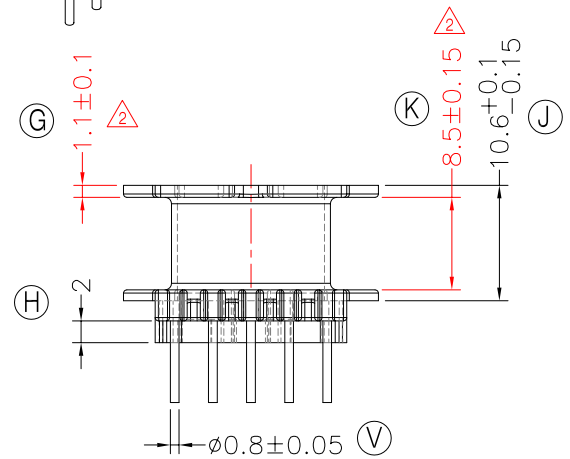
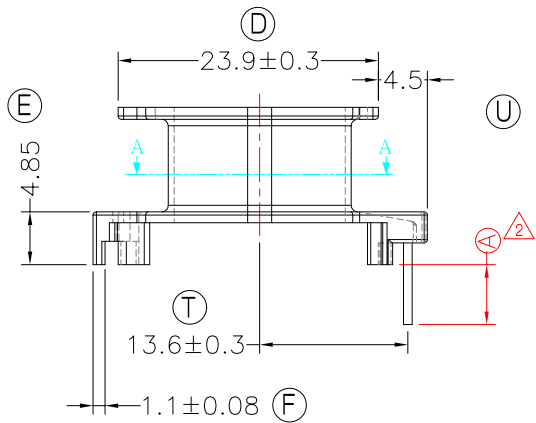
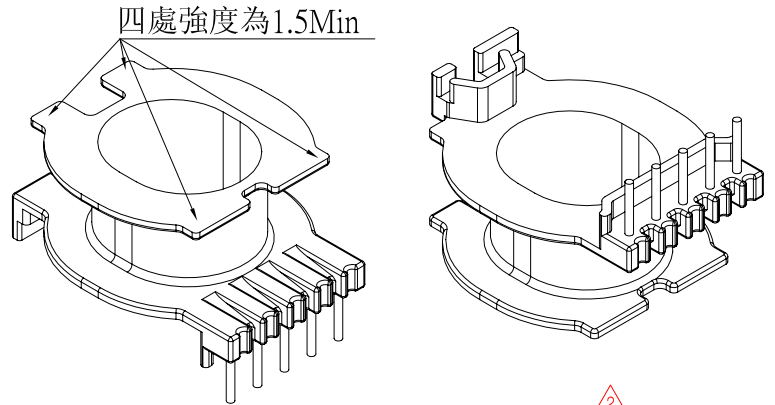
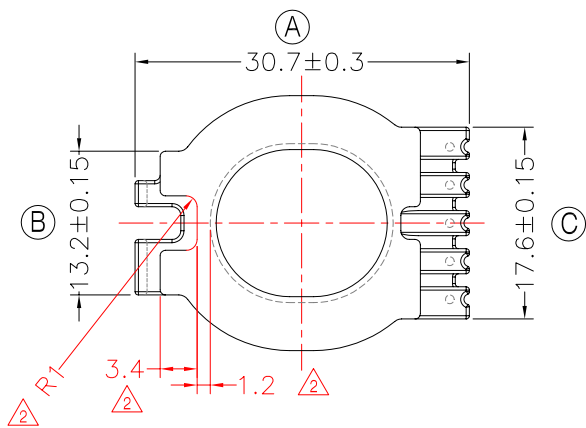

NOTE:

- 1.WINDING SPACE: 8.7mm*4.4mm=38.28mm²
 - 2.焊前拉力1.0kg Min 焊後拉力1.5kg Min;
 - 3.除特別指出處,任一點強度為1.8kg Min;
- 與TBI-238-07211.12XX(ATQ28-18.3B-1P-CASE-B1-12)配套使用;

DWG NO. ATQ28-18.3B-5P-TH-B0-12

PART NO.	MATERIAL (BOBBIN)	MATERIAL (TERMINAL)	TERMINAL (PLATING)	PIN ALLOCATION	NOTE
TBI-238-07201.1206	PM-9820	CP WIRE	Sn	ALL PIN (A)=5.5±0.3	S
TBI-238-07201.1216	PM-9820	CP WIRE	Sn	ALL PIN (A)=3.4+0.2/-0.3	暫無刀模 H

TOLERANCE: 0<L<=4:±0.1 4<L<=16:±0.2 16<L<=63:±0.3

UNIT : m / m

SCALE 1 : 1

Finish: 1. PB wire Immersion Sn on terminal : Thickness:Sn plating,100,5 μm (200 μ inches) min,Base nickel 0.625 μm (25 μ inches) min.
 2. CP wire Immersion Sn on terminal : Thickness:Sn plating,100,5 μm (200 μ inches) min.
 3. Coplanarity deviation: 0.10 mm (0.004 inches) max.

REV 2