



TRANSFORMER BOBBIN
INDUSTRIAL CO.,LTD.

Tel : 86-769-88789999 Fax : 86-769-88789989
http:// tbi-tw.com e-mail : tb6688@ms46.hinet.net

REVISIONS

REV	SYM	DRAFTER	CHECKER	DATE
△2		X.H.GU	G.F.YANG	06/06/15
△3		X.H.GU	G.F.YANG	12/01/15
△4		X.H.GU	G.F.YANG	07/14/16

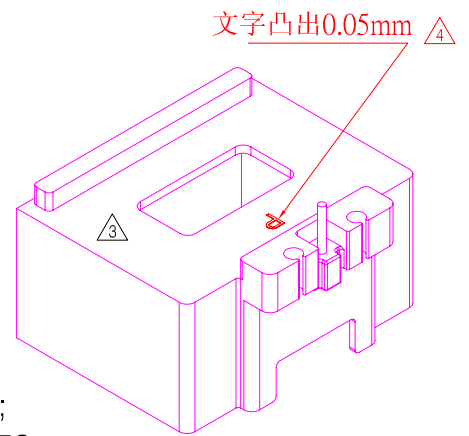
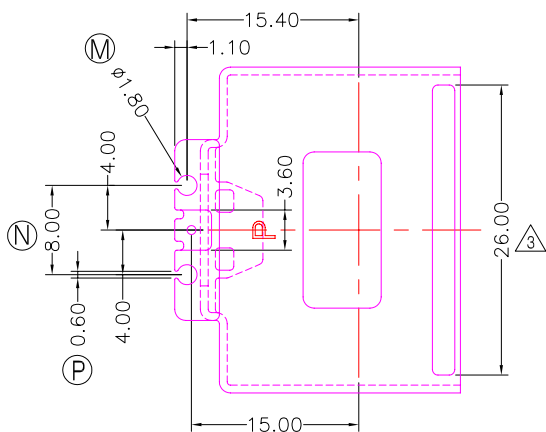
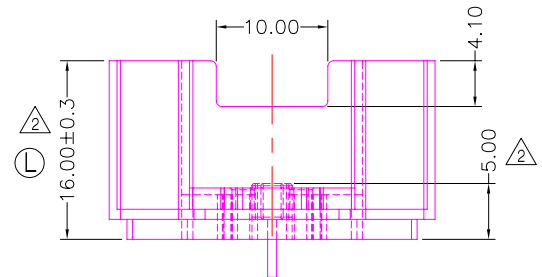
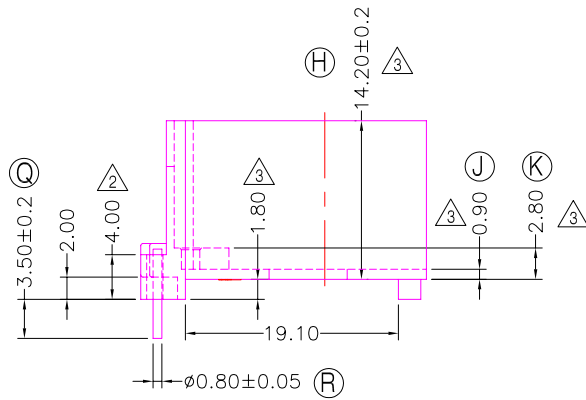
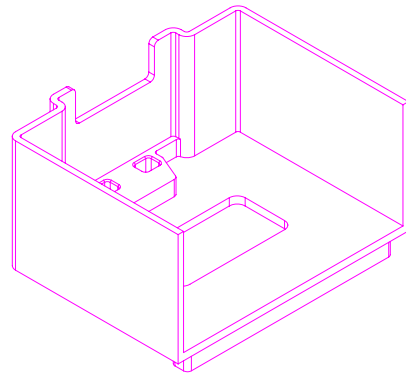
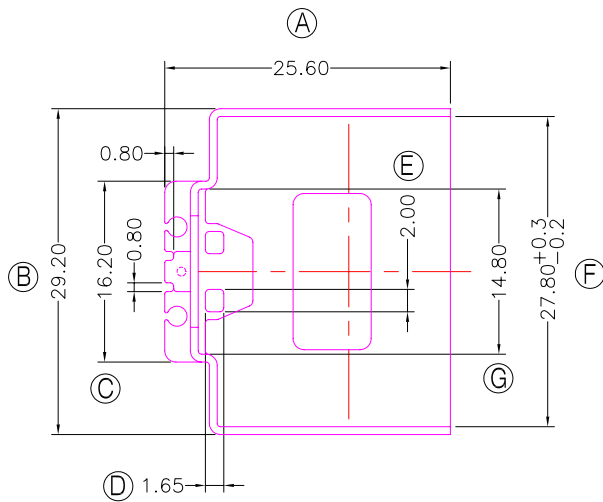

NOTE:

- 1.耐壓4.0Kv /1.5mA 60S;
 - 2.焊錫溫度:450°±10° 3SEC
 - 3.任一點的強度為1.5kg MIN;
 - 4.焊錫前拉力:1.0KG MIN,焊錫後拉力:1.5KG MIN;
- 與TBI-238-03951.12XX(ATQ27-14.4-5P-TH-J5-12)配套使用;

DWG NO. ATQ27-14.4-1P-CASE-J6-12

PART NO.	MATERIAL (BOBBIN)	MATERIAL (TERMINAL)	TERMINAL (PLATING)	PIN ALLOCATION	NOTE
TBI-238-03961.1206	PM-9820	CP WIRE	Sn	ALL PIN	S
TBI-238-03961.1216	PM-9820	CP WIRE	Sn	NO PIN	H

TOLERANCE:0<L<=4:±0.1 4<L<=16:±0.2 16<L<=63:±0.3

UNIT : m / m

SCALE 1 : 1

Finish: 1. PB wire Immersion Sn on terminal : Thickness:Sn plating,100%,5 μm (200 μ inches) min,Base nickel 0.625 μm (25 μ inches) min.
2. CP wire Immersion Sn on terminal : Thickness:Sn plating,100%,5 μm (200 μ inches) min.
3. Coplanarity deviation: 0.10 mm (0.004 inches) max.

REV 4