



TRANSFORMER BOBBIN
INDUSTRIAL CO.,LTD.

Tel : 86-769-88789999 Fax : 86-769-88789989
http:// tbi-tw.com e-mail : tb6688@ms46.hinet.net

REVISIONS

REV	SYM	DRAFTER	CHECKER	DATE
1		X.H.GU	G.F.YANG	06/14/12
2		X.H.GU	G.F.YANG	10/29/12
3				

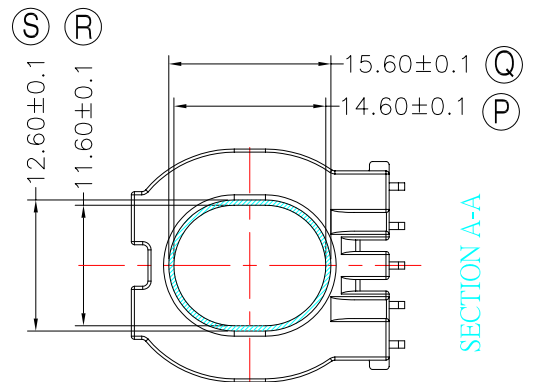
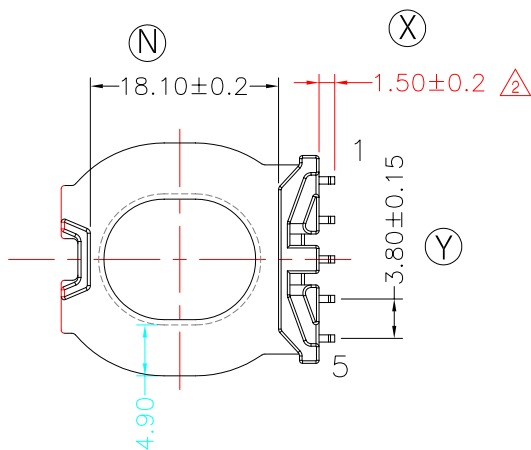
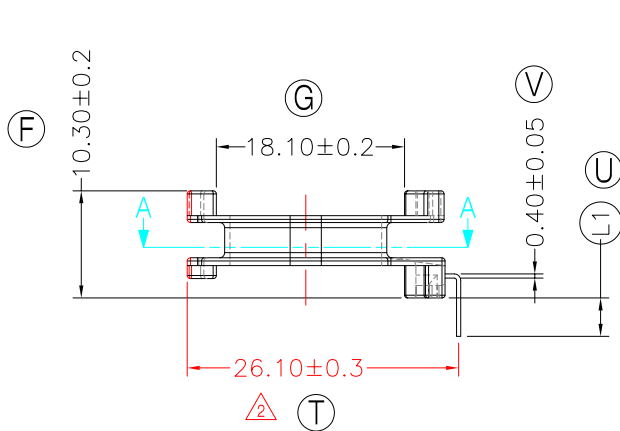
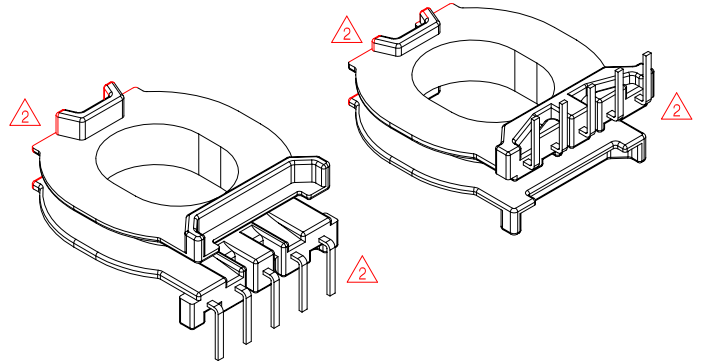
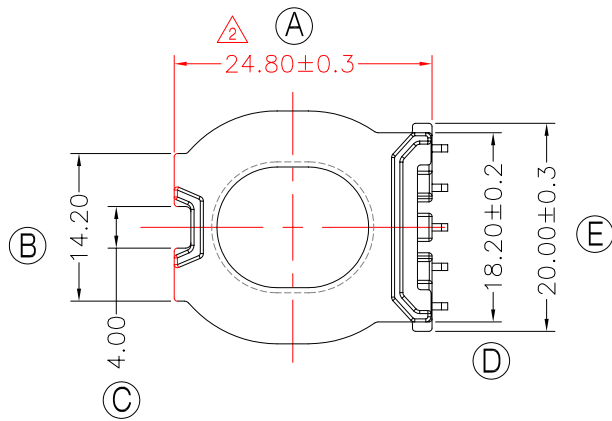

NOTE:

1. 任一點強度1.5kg Min
2. 焊前拉力:1.0kg Min; 焊後拉力1.5kg Min
3. WINDING SPACE:3.4mm*4.9mm=16.66 mm²

DWG NO. ATQ27-11-5P-TL-7D-11

PART NO.	MATERIAL (BOBBIN)	MATERIAL (TERMINAL)	TERMINAL (PLATING)	PIN ALLOCATION	NOTE
TBI-238-03741.1106	PM-9630	CP WIRE	Sn	ALL PIN (L1) = 3.7±0.3	S
TBI-238-03741.1116	PM-9630	CP WIRE	Sn	ALL PIN (L1) = 4.7±0.3	
TBI-238-03741.1126	PM-9630	CP WIRE	Sn	NO PIN#1 (L1) = 4.7±0.3	

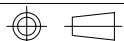

TOLERANCE: 0<L<=4:±0.1 4<L<=16:±0.2 16<L<=63:±0.3

UNIT : m / m

SCALE 1 : 1

Finish: 1. PB wire Immersion Sn on terminal : Thickness:Sn plating,100,5 μm (200 μ inches) min,Base nickel 0.625 μm (25 μ inches) min.
2. CP wire Immersion Sn on terminal : Thickness:Sn plating,100,5 μm (200 μ inches) min.
3. Coplanarity deviation: 0.10 mm (0.004 inches) max.

REV 2