



TRANSFORMER BOBBIN
INDUSTRIAL CO.,LTD.

Tel : 86-769-88789999 Fax : 86-769-88789989
http:// tbi-tw.com e-mail : tb6688@ms46.hinet.net

REVISIONS

REV	SYM	DRAFTER	CHECKER	DATE
2		X.H.GU	G.F.YANG	07/01/14
3		X.H.GU	G.F.YANG	09/17/14
4		X.H.GU	G.F.YANG	11/07/16

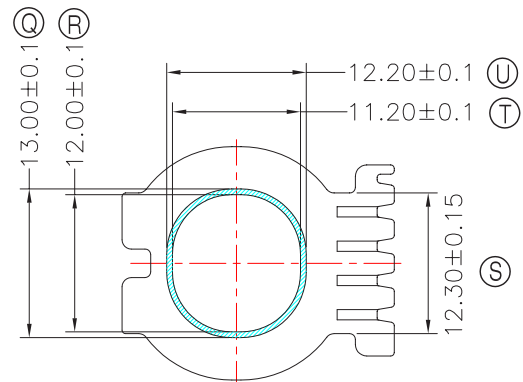
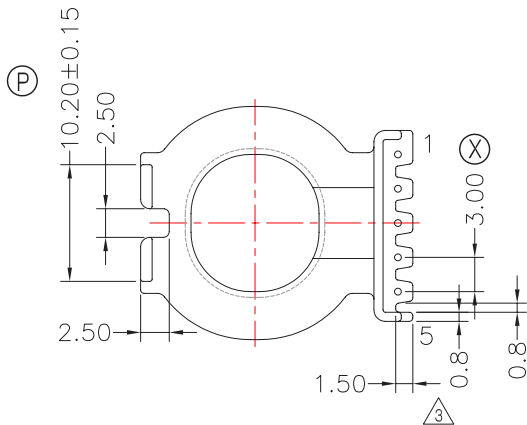
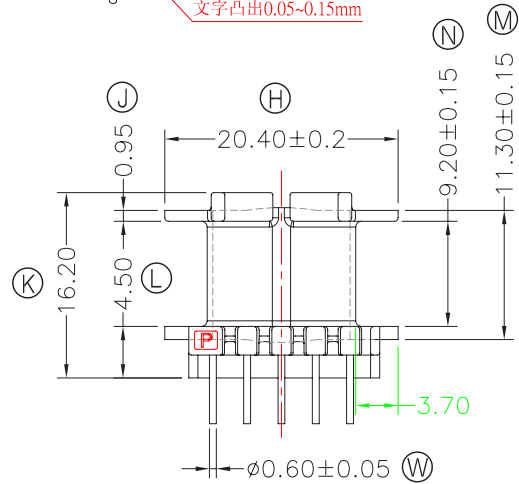
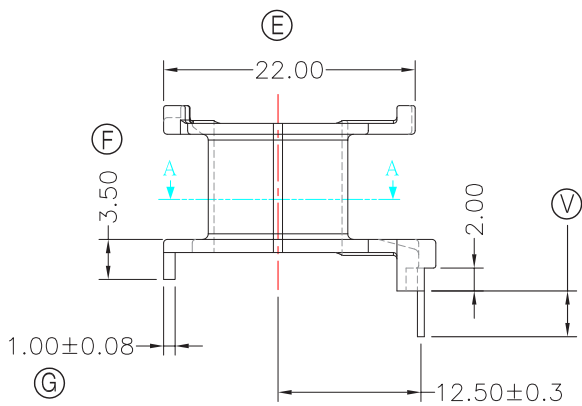
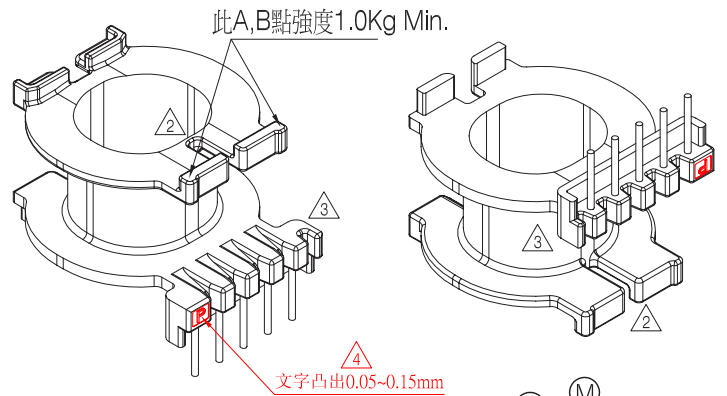
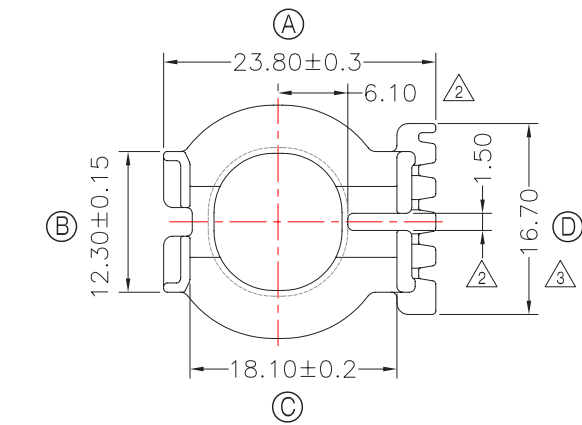

NOTE:

Section A-A

1. 焊錫前拉力:1.0KG MIN, 焊錫後拉力:1.5KG MIN;
2. 任意一點強度須1.8kg MIN;(除了特別指出外)
3. WINDING SPACE:9.2mm*3.7mm=34.04mm² 與TBI-238-01501.12C(ATQ24-17A-CASE-E0-12)配套使用;

DWG NO. ATQ24-17A-5P-TH-E0-12

PART NO.	MATERIAL (BOBBIN)	MATERIAL (TERMINAL)	TERMINAL (PLATING)	PIN ALLOCATION	NOTE
TBI-238-01501.1206	PM-9820	CP WIRE	Sn	ALL PIN (V) =4.0±0.2	S
TBI-238-01501.1216	PM-9820	CP WIRE	Sn	ALL PIN (V) =5.5±0.2	H
TBI-238-01501.1226	PM-9820	CP WIRE	Sn	ALL PIN (V) =5.0±0.2	

TOLERANCE: 0<L<=4:±0.1 4<L<=16:±0.2 16<L<=63:±0.3

UNIT : m / m

SCALE 1 : 1

Finish: 1. PB wire Immersion Sn on terminal : Thickness:Sn plating,100%,5 μm (200 μ inches) min,Base nickel 0.625 μm (25 μ inches) min.
2. CP wire Immersion Sn on terminal : Thickness:Sn plating,100%,5 μm (200 μ inches) min.
3. Coplanarity deviation: 0.10 mm (0.004 inches) max.

REV 4