

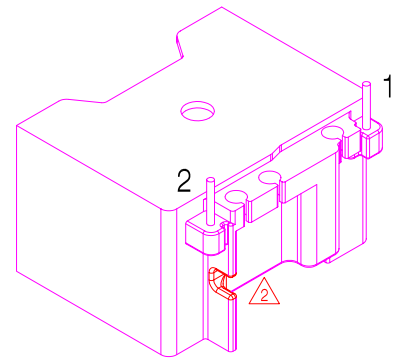

TRANSFORMER BOBBIN  
INDUSTRIAL CO.,LTD.

Tel : 86-769-88789999 Fax : 86-769-88789999  
http:// tbi-tw.com e-mail : tb6688@ms46.hinet.net

REVISIONS				
REV	SYM	DRAFTER	CHECKER	DATE
△1		X.H.GU	G.F.YANG	04/08/16
△2		X.H.GU	G.F.YANG	05/03/16
△3				

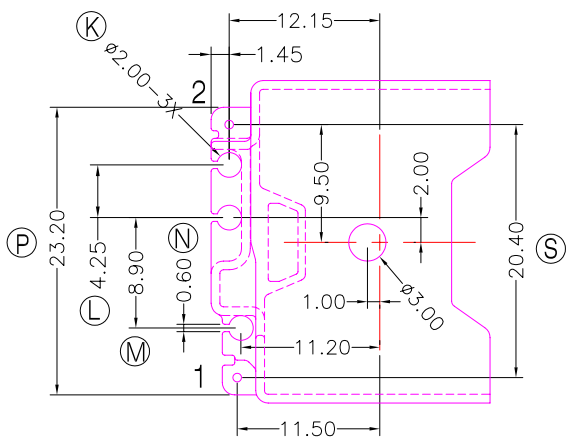
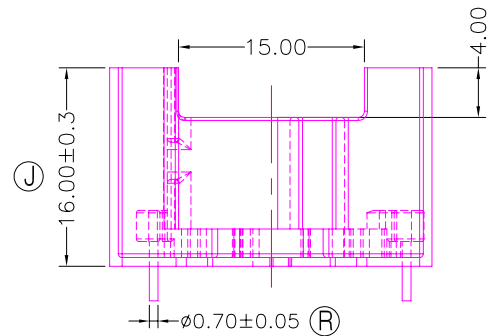
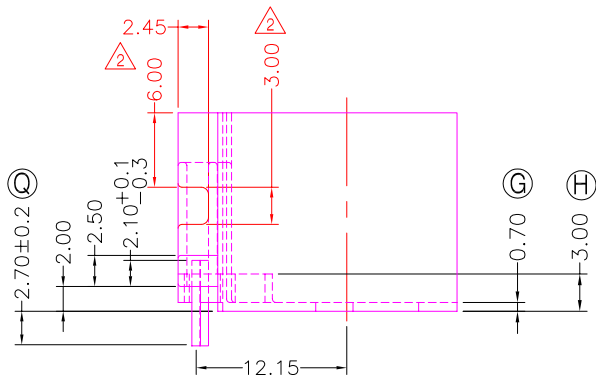
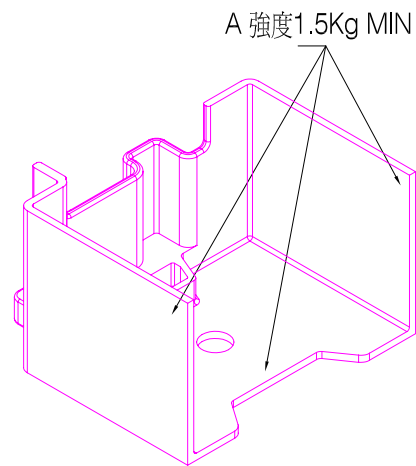
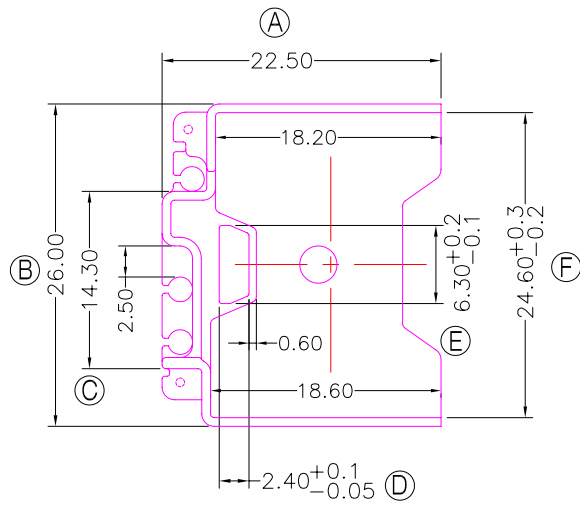

NOTE:

- 1.耐壓4.0Kv /1.5mA 60S;
  - 2.焊錫溫度:450°±10° 3SEC
  - 3.焊錫前拉力:1.0KG MIN,焊錫後拉力:1.5KG MIN;
  - 4.任一點的強度為1.8kg MIN, 其中.A處為1.5kg MIN
- 與TBI-238-10411.11XX(ATQ23.7-16.7A-7P-TH-D1-11)配套使用;

DWG NO. ATQ23.7-16.7A-2P-CASE-D9-11

PART NO.	MATERIAL (BOBBIN)	MATERIAL (TERMINAL)	TERMINAL (PLATING)	PIN ALLOCATION	NOTE
TBI-238-10491.1106	PM-9630	CP WIRE	Sn	ALL PIN	S
TBI-238-10491.1116	PM-9630	CP WIRE	Sn	NO PIN#1	

TOLERANCE:0<L<=4:±0.1 4<L<=16:±0.2 16<L<=63:±0.3

UNIT : m / m

SCALE 1 : 1

Finish: 1. PB wire Immersion Sn on terminal : Thickness:Sn plating,100%,5 μm (200 μ inches) min,Base nickel 0.625 μm (25 μ inches) min.  
2. CP wire Immersion Sn on terminal : Thickness:Sn plating,100%,5 μm (200 μ inches) min.  
3. Coplanarity deviation: 0.10 mm (0.004 inches) max.

REV 2