



**TRANSFORMER BOBBIN
INDUSTRIAL CO.,LTD.**

Tel : 86-769-88789999 Fax : 86-769-88789989
http:// tbi-tw.com e-mail : tb688@ms46.hinet.net

REVISIONS

REV	SYM	DRAFTER	CHECKER	DATE
1		X.H.GU	G.F.YANG	05/12/16
2				
3				

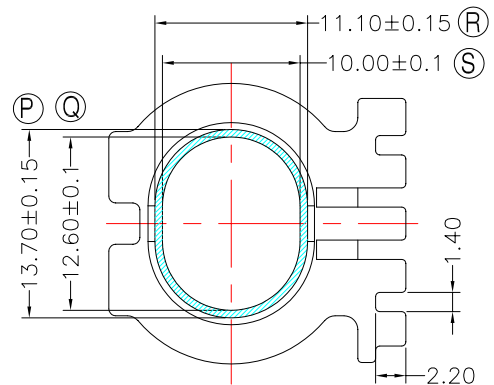
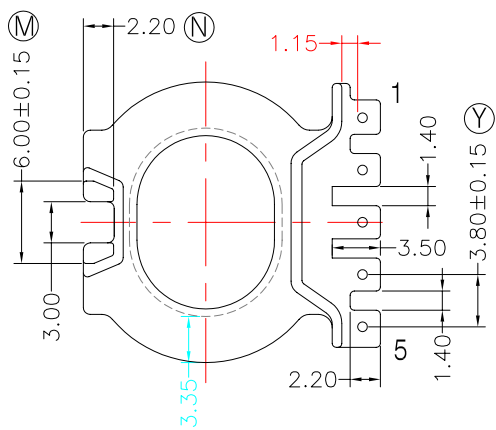
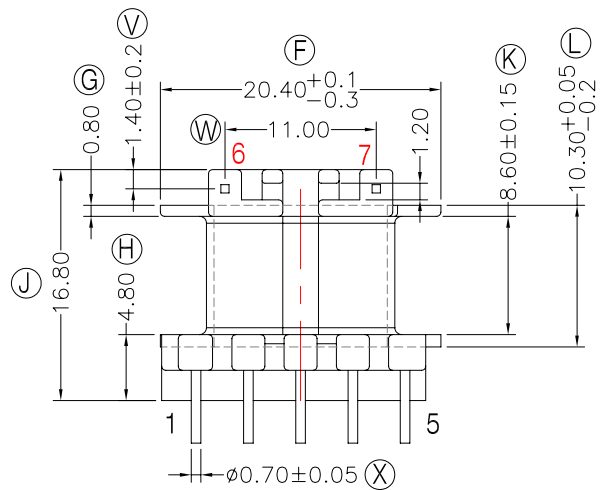
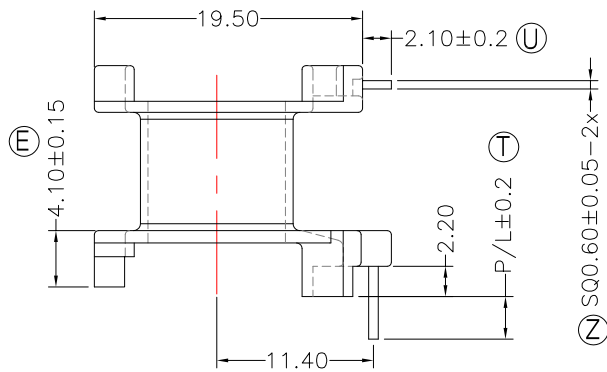
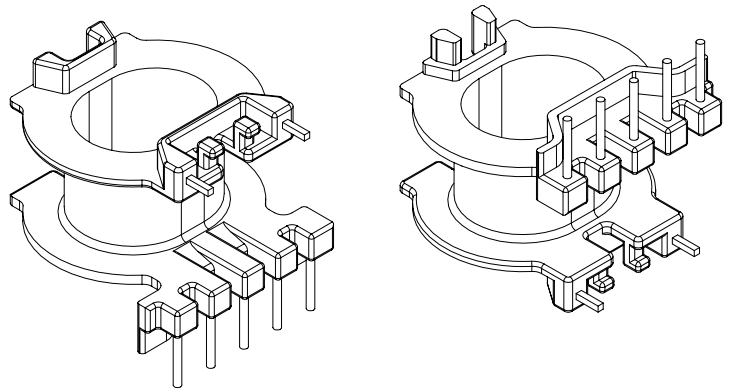
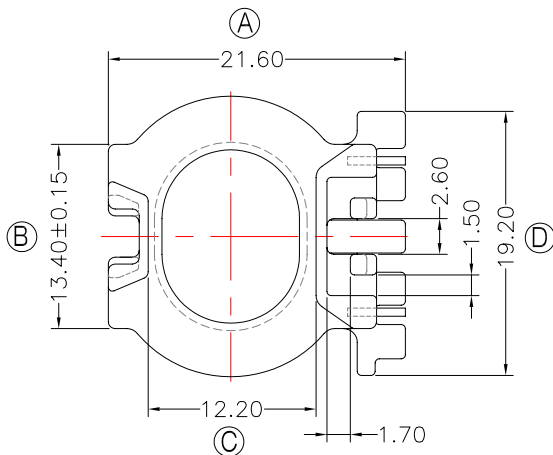

NOTE:

- 1.耐壓4.0Kv /1.5mA 60S;
- 2.焊錫溫度:450°±10° 3SEC
- 3.任意一點強度須1.5kg MIN;
- 4.焊錫前拉力:1.0KG MIN,焊錫後拉力:1.5KG MIN;
- 5.Winding Space=8.6*3.35=28.81mm ^2

DWG NO. ATQ23.7-16.7A-7P-TH-D1-17

PART NO.	MATERIAL (BOBBIN)	MATERIAL (TERMINAL)	TERMINAL (PLATING)	PIN ALLOCATION	NOTE
TBI-238-10411.1706	PM-9823	CP WIRE	Sn	ALL PIN P/L=5.0±0.2	S
TBI-238-10411.1716	PM-9823	CP WIRE	Sn	CUT PIN#6 P/L=5.0±0.2	H
TBI-238-10411.1726	PM-9823	CP WIRE	Sn	CUT PIN#2,6 P/L=5.0±0.2	

TOLERANCE: 0<L<=4: ±0.1 4<L<=16: ±0.2 16<L<=63: ±0.3 UNIT : m / m SCALE 1 : 1

Finish: 1. PB wire Immersion Sn on terminal : Thickness:Sn plating,100%,5 μm (200 μ inches) min,Base nickel 0.625 μm (25 μ inches) min.
2. CP wire Immersion Sn on terminal : Thickness:Sn plating,100%,5 μm (200 μ inches) min.
3. Coplanarity deviation: 0.10 mm (0.004 inches) max.

REV 1