



TRANSFORMER BOBBIN INDUSTRIAL CO.,LTD.

Tel : 86-769-88789999 Fax : 86-769-88789989
 http:// tbi-tw.com e-mail : tb6688@ms46.hinet.net

REVISIONS

REV	SYM	DRAFTER	CHECKER	DATE
①		X.H.GU	G.F.YANG	10/20/16
②				
③				

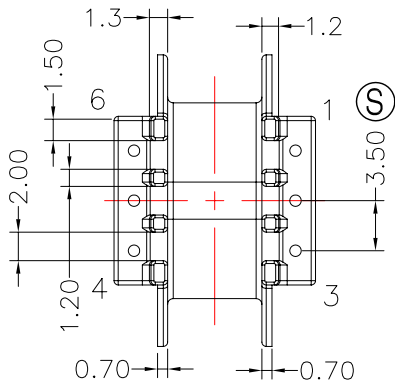
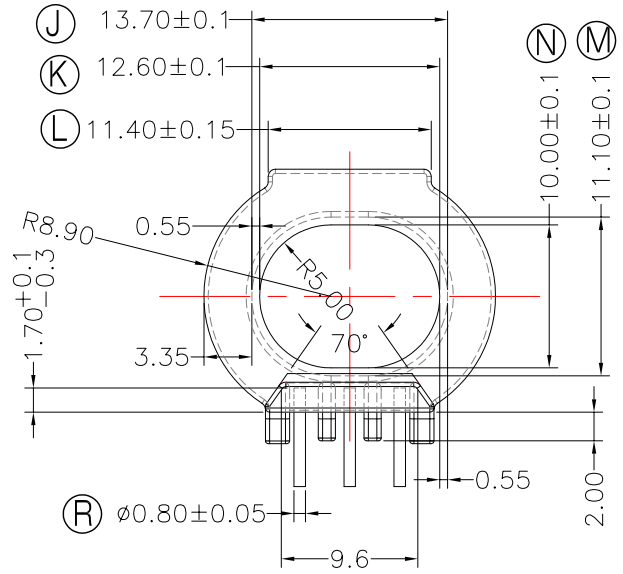
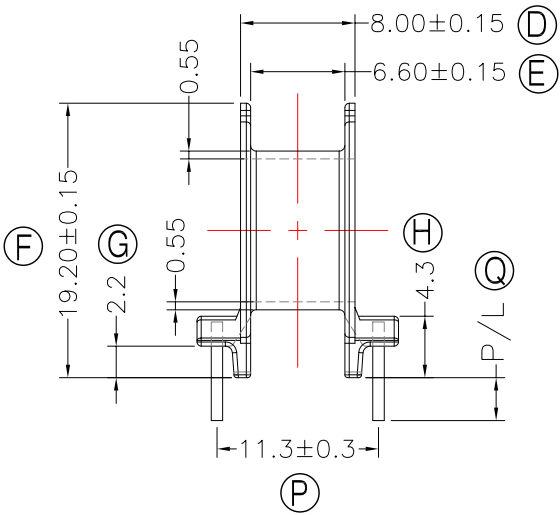
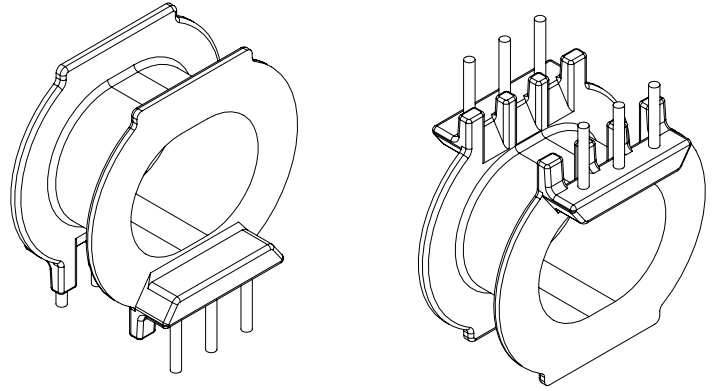
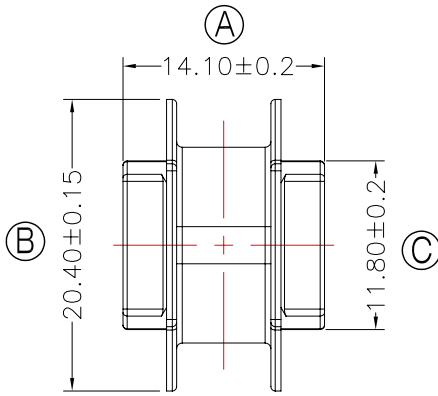

NOTE:

- 1.任一點的強度為1.5kgMIN.
- 2.耐壓4.0Kv /1.5mA 60S;
- 3.焊錫溫度:450° ±10° 3SEC
- 4.PIN拉力須焊前1.0KgMIN焊后1.5KgMIN.
- 5.Winding Space=6.6*3.35=22.11mm ^2

DWG NO.	ATQ23.7-14.6-6P-TH-E-17				
PART NO.	MATERIAL (BOBBIN)	MATERIAL (TERMINAL)	TERMINAL (PLATING)	PIN ALLOCATION	NOTE
TBI-238-10051.1706	PM-9823	CP WIRE	Sn	ALL PIN P/L=2.9±0.2	S
TBI-238-10051.1716	PM-9823	CP WIRE	Sn	CUT PIN#2,6 P/L=2.9±0.2	H
	TOLERANCE: 0 < L <= 4: ±0.1 4 < L <= 16: ±0.2 16 < L <= 63: ±0.3			UNIT : m / m	SCALE 1 : 1

Finish: 1. PB wire Immersion Sn on terminal : Thickness:Sn plating,100%,5 μ m (200 μ inches) min,Base nickel 0.625 μ m (25 μ inches) min.
 2. CP wire Immersion Sn on terminal : Thickness:Sn plating,100%,5 μ m (200 μ inches) min.
 3. Coplanarity deviation: 0.10 mm (0.004 inches) max.

REV 1