

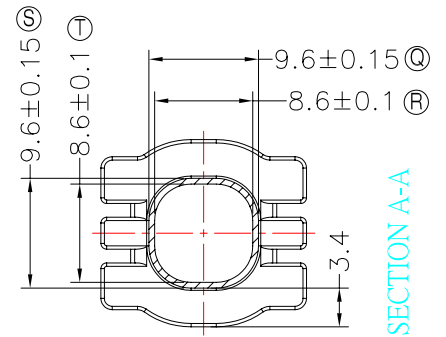

**TRANSFORMER BOBBIN
INDUSTRIAL CO.,LTD.**

Tel : 86-769-88789999 Fax : 86-769-88789989
http:// tbi-tw.com e-mail : tb6688@ms46.hinet.net

REVISIONS				
REV	SYM	DRAFTER	CHECKER	DATE
①		M.WANG	G.F.YANG	12/14/16
②				
③				

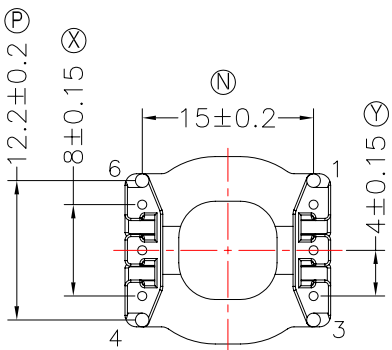
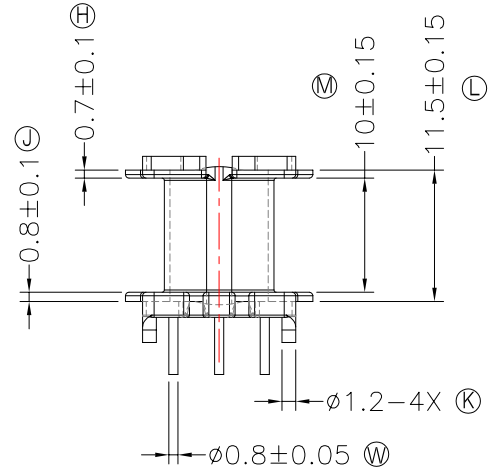
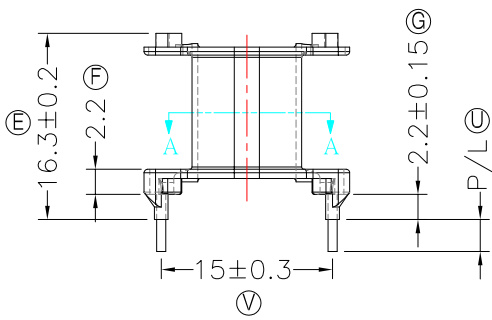
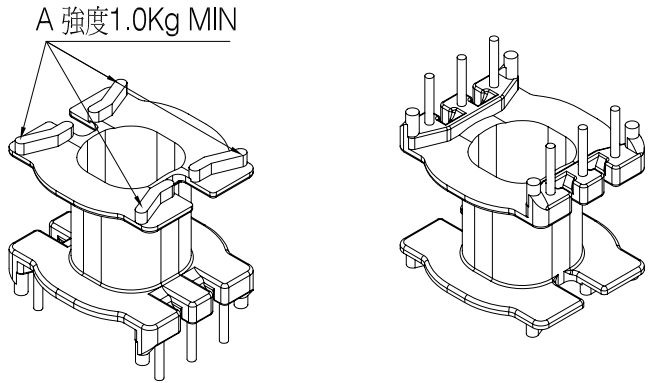
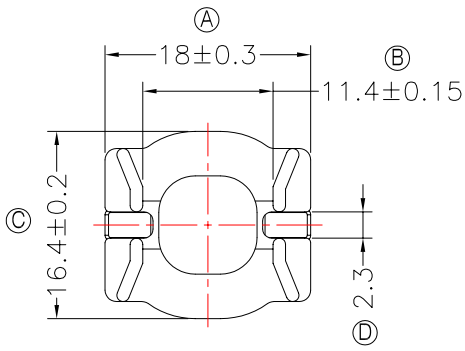

NOTE:

- 1.耐壓4.0Kv /1.5mA 60S;
- 2.焊錫溫度:450°±10° 3SEC
- 3.焊錫前拉力:1.0KG MIN,焊錫後拉力:1.5KG MIN;
- 4.任意一點強度須1.5kg MIN(其中 A 處強度為1.0KG MIN);
- 5.WINDING SPACE: 3.4mm*10mm=34mm²

DWG NO.	ATQ21-16.8-6P-TH-D-17				
PART NO.	MATERIAL (BOBBIN)	MATERIAL (TERMINAL)	TERMINAL (PLATING)	PIN ALLOCATION	NOTE
TBI-238-13041.1706	PM-9823	CP WIRE	Sn	ALL PIN P/L=2.8±0.2	S
TBI-238-13041.1716	PM-9823	CP WIRE	Sn	CUT PIN #3,5 P/L=3.5±0.2	H

	TOLERANCE: 0<L≤4:±0.1 4<L≤16:±0.2 16<L≤63:±0.3	UNIT : m / m	SCALE 1 : 1
Finish:	1. PB wire Immersion Sn on terminal : Thickness:Sn plating,100%,5 μm (200 μ inches) min,Base nickel 0.625 μm (25 μ inches) min. 2. CP wire Immersion Sn on terminal : Thickness:Sn plating,100%,5 μm (200 μ inches) min. 3. Coplanarity deviation: 0.10 mm (0.004 inches) max.		REV 1