



**TRANSFORMER BOBBIN
INDUSTRIAL CO.,LTD.**

Tel : 86-769-88789999 Fax : 86-769-88789989
http:// tbi-tw.com e-mail : tb6688@ms46.hinet.net

REVISIONS

| REV | SYM | DRAFTER | CHECKER | DATE |
|-----|-----|---------|----------|----------|
| 1 | | M.WANG | G.F.YANG | 08/01/16 |
| 2 | | | | |
| 3 | | | | |

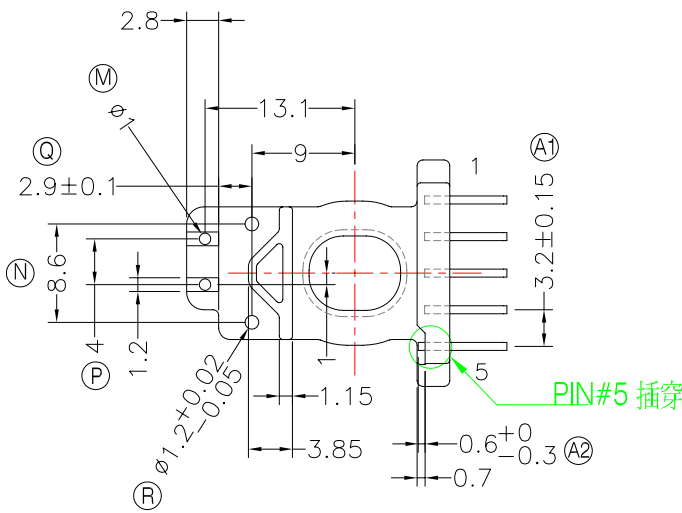
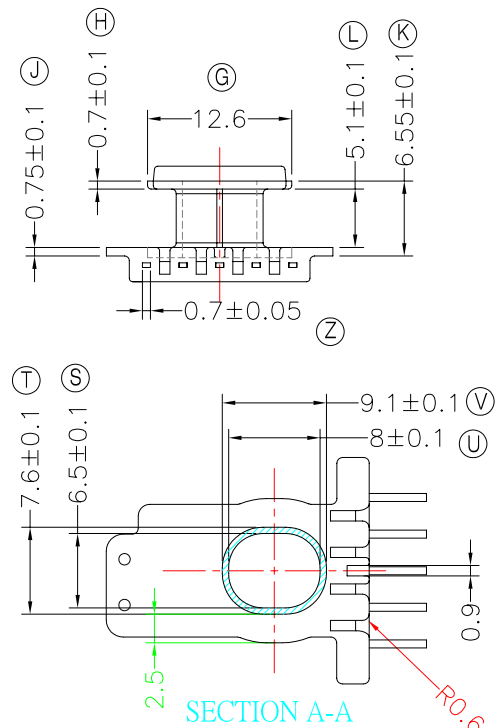
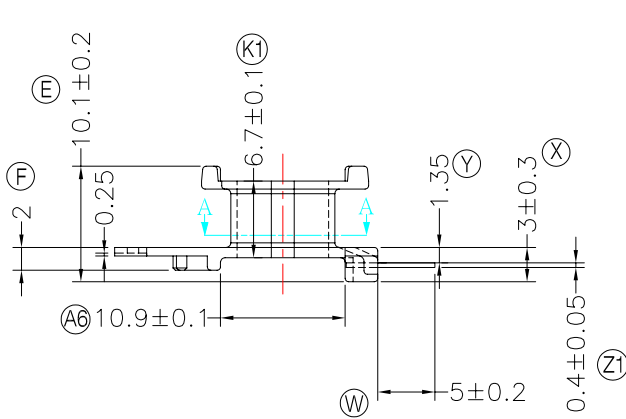
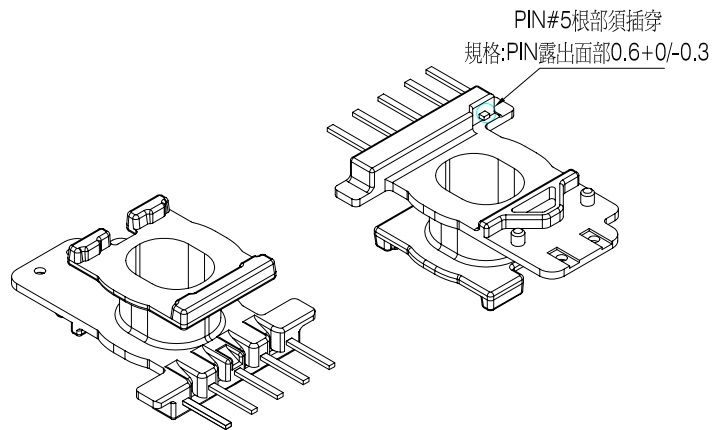
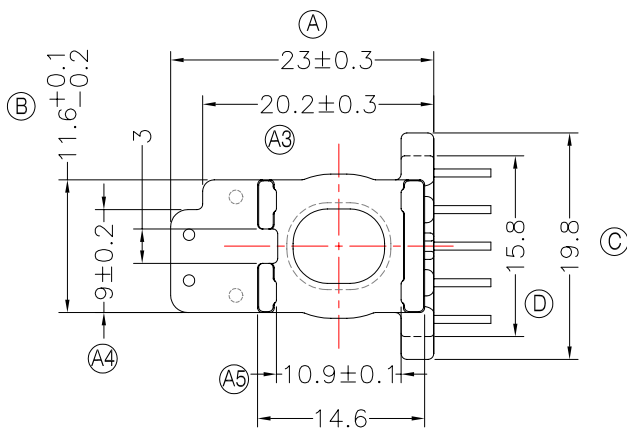

NOTE:

1. 焊錫前拉力:1.0KG MIN, 焊錫後拉力:1.5KG MIN;
2. 任意一點強度須1.5kg MIN;
3. 耐壓4.0Kv /1.5mA 60S;
4. 焊錫溫度:450°±10° 3SEC;
5. PIN切面100%鍍錫, 不可氧化;
6. WINDING SPACE:5.1mm*2.5mm=12.75mm²

DWG NO. ATQ17-10.9A-5P-TH-3C-11

| PART NO. | MATERIAL (BOBBIN) | MATERIAL (TERMINAL) | TERMINAL (PLATING) | PIN ALLOCATION | NOTE |
|---|-------------------|---------------------|--------------------|----------------|-------------|
| TBI-238-26331.1106 | PM-9630 | CP WIRE | Sn | ALL PIN | S H |
| TOLERANCE: 0<L<=4:±0.1 4<L<=16:±0.2 16<L<=63:±0.3 | | | | UNIT : m / m | SCALE 1 : 1 |

Finish: 1. PB wire Immersion Sn on terminal : Thickness:Sn plating,100%,5 μm (200 μ inches) min,Base nickel 0.625 μm (25 μ inches) min.
2. CP wire Immersion Sn on terminal : Thickness:Sn plating,100%,5 μm (200 μ inches) min.
3. Coplanarity deviation: 0.10 mm (0.004 inches) max.

REV 1