



**TRANSFORMER BOBBIN
INDUSTRIAL CO.,LTD.**

Tel : 86-769-88789999 Fax : 86-769-88789989
http:// tbi-tw.com e-mail : tb6688@ms46.hinet.net

REVISIONS

REV	SYM	DRAFTER	CHECKER	DATE
①		X.H.GU	G.F.YANG	02/17/16
②				
③				

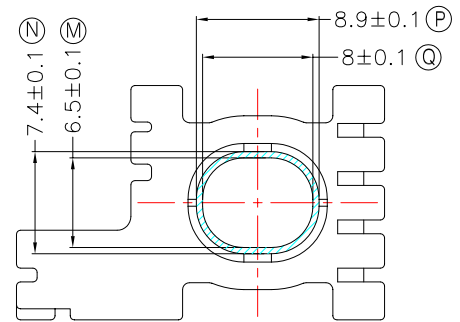
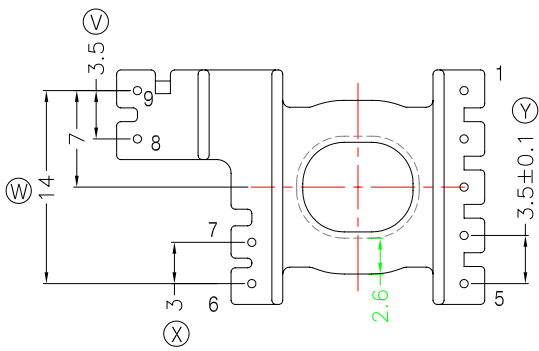
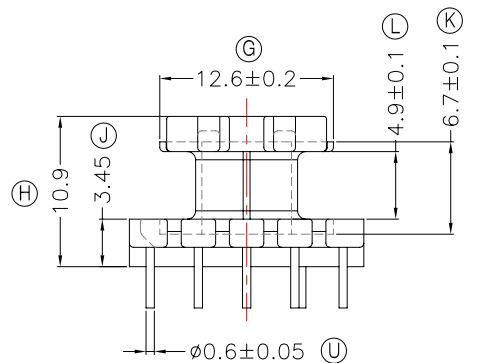
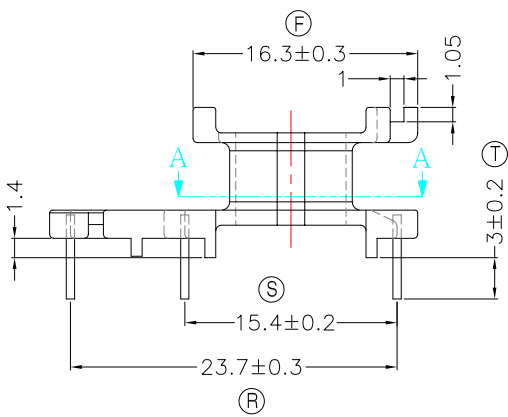
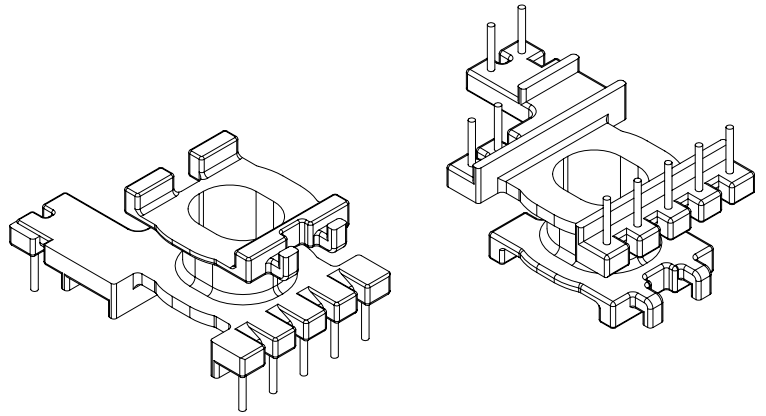
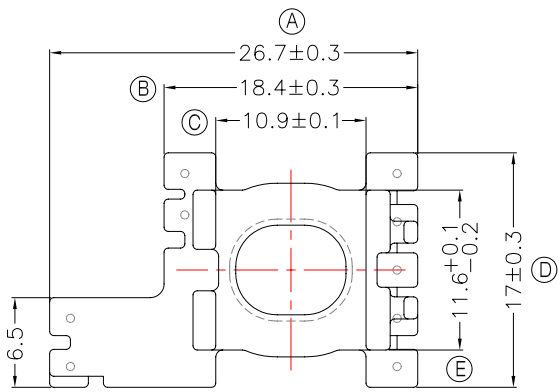

NOTE:

1. 焊錫前拉力: 2.0KG MIN
2. 任意一點強度須 1.5kg MIN;
3. WINDING SPACE: 5.1mm*2.6mm=13.26mm²

DWG NO. ATQ17-10.9A-9P-TH-C0-11

PART NO.	MATERIAL (BOBBIN)	MATERIAL (TERMINAL)	TERMINAL (PLATING)	PIN ALLOCATION	NOTE
TBI-238-26301.1106	PM-9630	CP WIRE	Sn	ALL PIN	S

TOLERANCE: 0<L<=4:±0.1 4<L<=16:±0.2 16<L<=63:±0.3 UNIT : m / m SCALE 1 : 1

Finish: 1. PB wire Immersion Sn on terminal : Thickness: Sn plating, 100%, 5 μm (200 μ inches) min, Base nickel 0.625 μm (25 μ inches) min.
2. CP wire Immersion Sn on terminal : Thickness: Sn plating, 100%, 5 μm (200 μ inches) min.
3. Coplanarity deviation: 0.10 mm (0.004 inches) max.

REV 1