

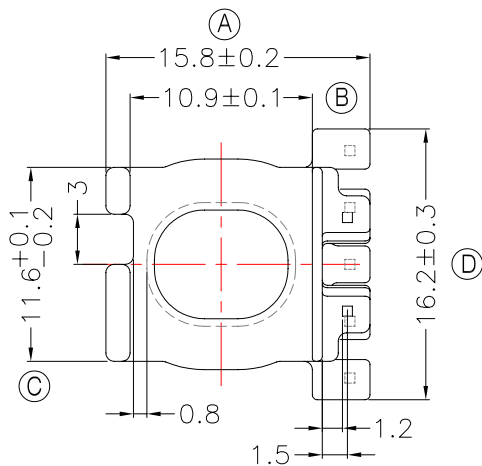

TRANSFORMER BOBBIN  
INDUSTRIAL CO.,LTD.

Tel : 86-769-88789999 Fax : 86-769-88789989  
http:// tbi-tw.com e-mail : tb6688@ms46.hinet.net

REVISIONS				
REV	SYM	DRAFTER	CHECKER	DATE
①		X.H.GU	G.F.YANG	11/09/15
②				
③				



A 強度1.0Kg MIN

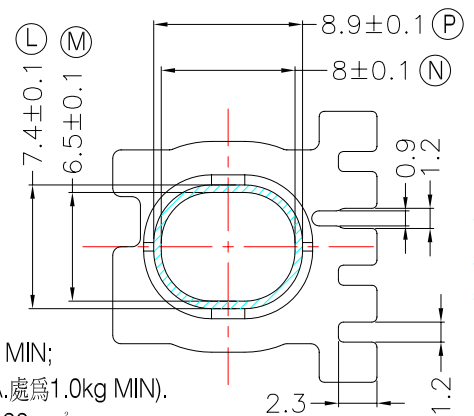
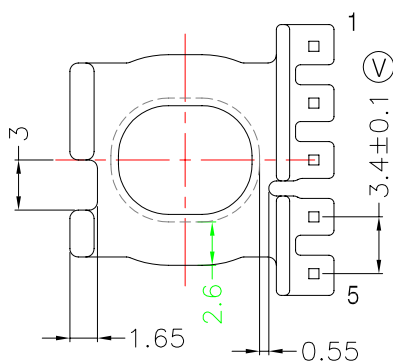
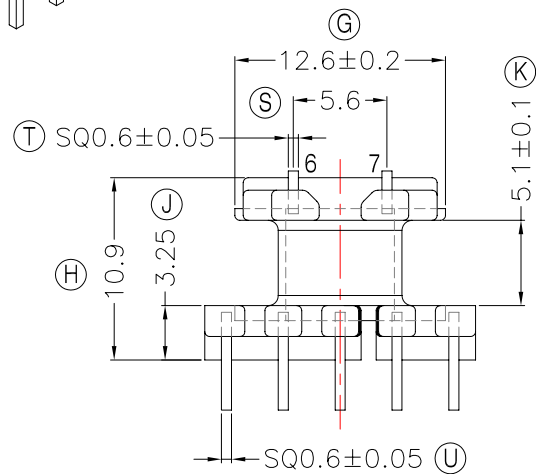
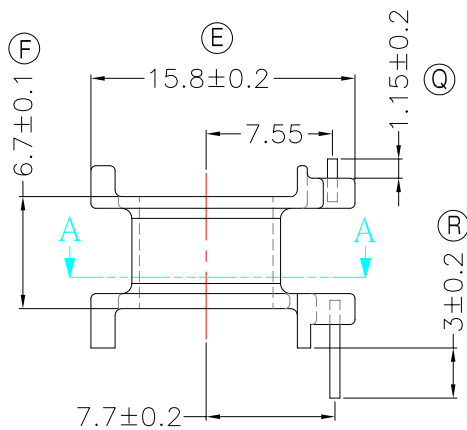
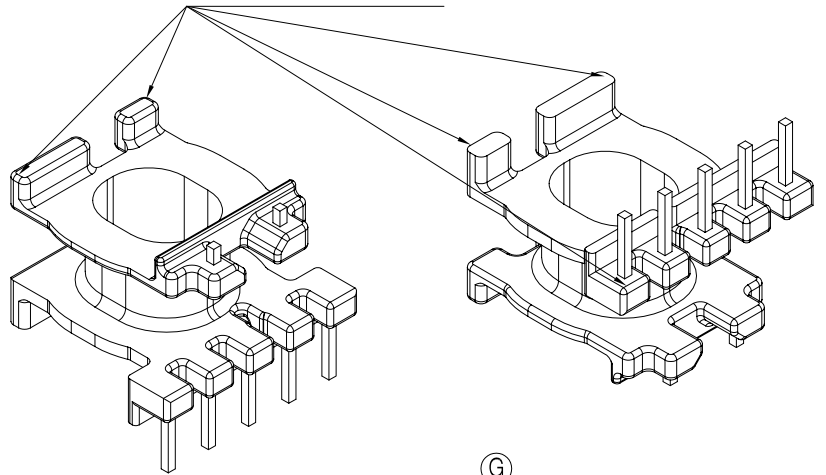

SECTION A-A

NOTE:

- 1.耐壓4.0Kv /1.5mA 60S;
- 2.焊錫溫度:450°±10° 3SEC;
- 3.焊錫前拉力:1.0KG MIN,焊錫後拉力:1.5KG MIN;
- 4.任意一點強度須1.5kg MIN;(除以下測試點.A.處為1.0kg MIN).
- 5.WINDING SPACE: 5.1mm\*2.6mm=13.26mm<sup>2</sup>

DWG NO. ATQ17-10.9A-7P-TH-B7-11

PART NO.	MATERIAL (BOBBIN)	MATERIAL (TERMINAL)	TERMINAL (PLATING)	PIN ALLOCATION	NOTE
----------	-------------------	---------------------	--------------------	----------------	------

TBI-238-26271.1106	PM-9630	CP WIRE	Sn	ALL PIN	S
--------------------	---------	---------	----	---------	---

TOLERANCE: 0<L<=4:±0.1 4<L<=16:±0.2 16<L<=63:±0.3

UNIT : m / m

SCALE 1 : 1

Finish: 1. PB wire Immersion Sn on terminal : Thickness:Sn plating,100%,5 μm (200 μ inches) min,Base nickel 0.625 μm (25 μ inches) min.  
2. CP wire Immersion Sn on terminal : Thickness:Sn plating,100%,5 μm (200 μ inches) min.  
3. Coplanarity deviation: 0.10 mm (0.004 inches) max.

REV 1