



TRANSFORMER BOBBIN
INDUSTRIAL CO.,LTD.

Tel : 86-769-88789999 Fax : 86-769-88789989
http:// tbi-tw.com e-mail : tb6688@ms46.hinet.net

REVISIONS

REV	SYM	DRAFTER	CHECKER	DATE
1		X.H.GU	G.F.YANG	09/19/14
2				
3				

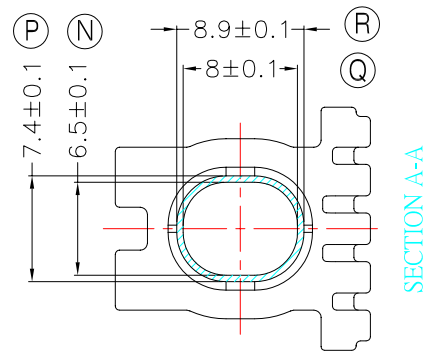
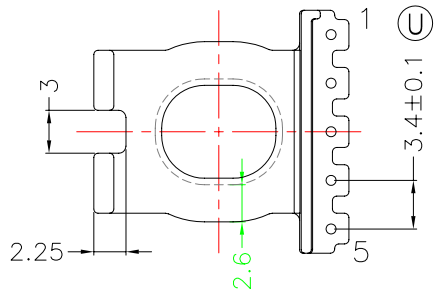
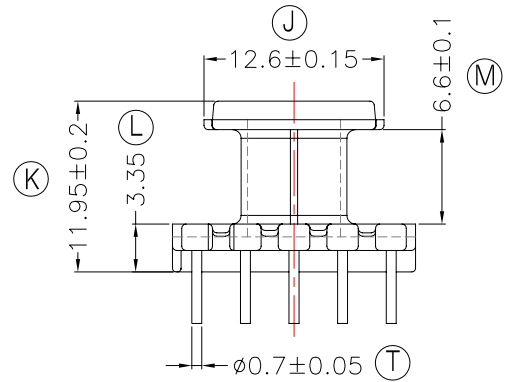
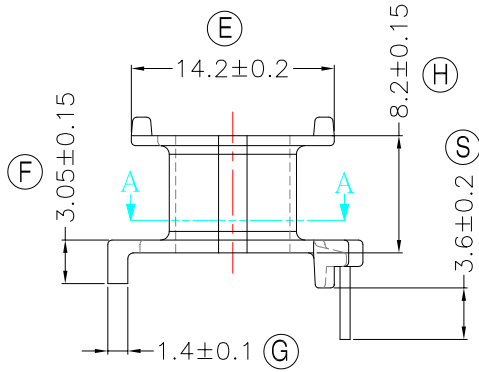
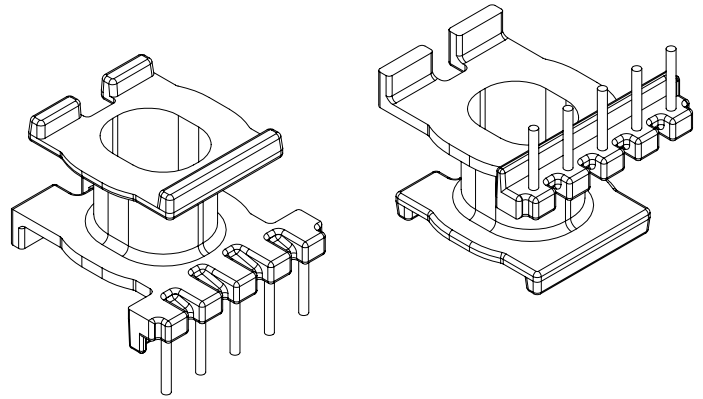
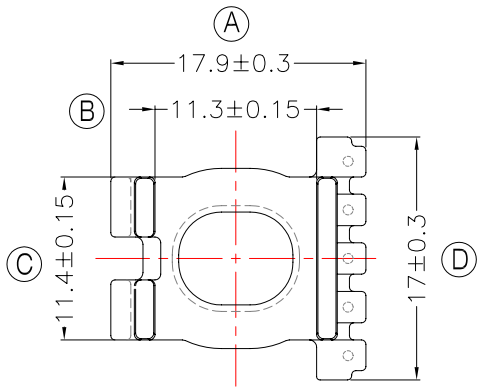

WINDING SPACE: 6.6mm*2.6mm=17.16mm²
與TBI-238-26141.12C(ATQ17-12.4A-CASE-A4-12)配套使用;

DWG NO. ATQ17-12.4A-5P-TH-A4-12

PART NO.	MATERIAL (BOBBIN)	MATERIAL (TERMINAL)	TERMINAL (PLATING)	PIN ALLOCATION	NOTE
TBI-238-26141.1206	PM-9820	CP WIRE	Sn	ALL PIN	S
TOLERANCE: 0<L≤4:±0.1 4<L≤16:±0.2 16<L≤63:±0.3				UNIT : m / m	SCALE 1 : 1

Finish: 1. PB wire Immersion Sn on terminal : Thickness:Sn plating,100%,5 μm (200 μ inches) min,Base nickel 0.625 μm (25 μ inches) min.
2. CP wire Immersion Sn on terminal : Thickness:Sn plating,100%,5 μm (200 μ inches) min.
3. Coplanarity deviation: 0.10 mm (0.004 inches) max.

REV 1