



TRANSFORMER BOBBIN
INDUSTRIAL CO.,LTD.

Tel : 86-769-88789999 Fax : 86-769-88789989
http:// tbi-tw.com e-mail : tb6688@ms46.hinet.net

REVISIONS

REV	SYM	DRAFTER	CHECKER	DATE
1		X.X.YUAN	G.F.YANG	08/14/15
2		X.H.GU	G.F.YANG	10/30/15
3				

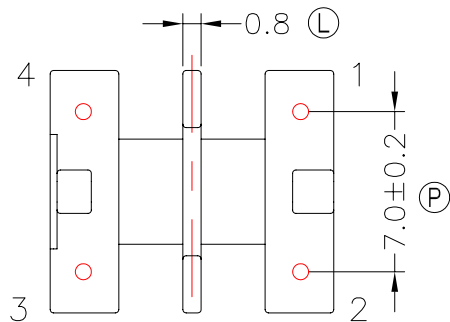
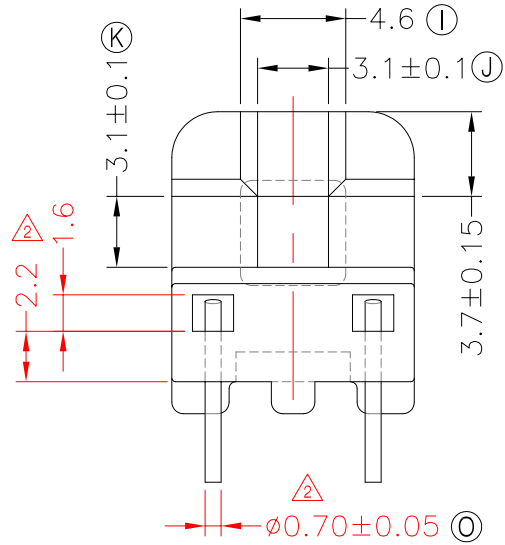
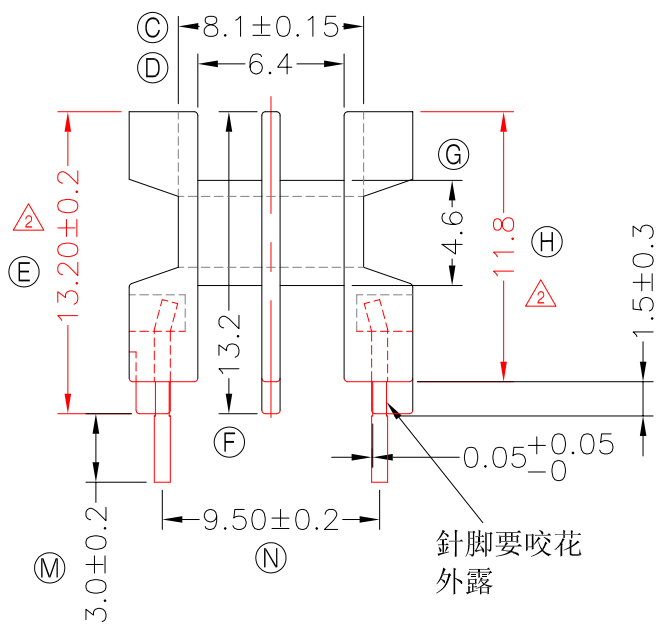
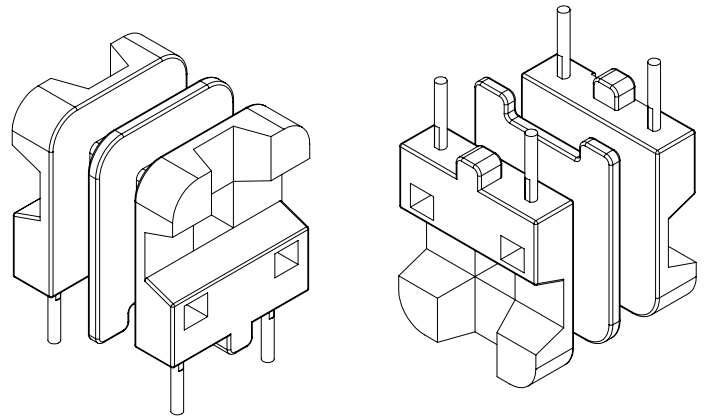
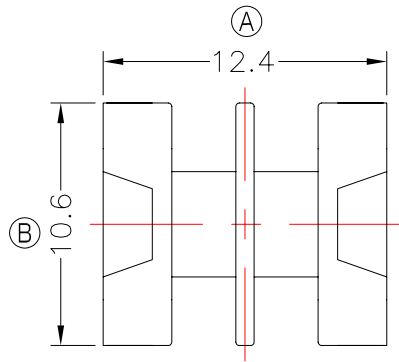

NOTE:

- 1.耐壓4.0Kv /1.5mA 60S;
- 2.焊錫溫度:450°±10° 3SEC;
- 3.焊錫前拉力:2.5KG MIN,焊錫後拉力:3.0KG MIN;
- 4.PIN根部咬花要外露,規格:寬度1.5±0.3,深度0.05Min;
- 5.任意一點強度須2.0kg MIN(其中中間葉片強度1.5KG MIN);

DWG NO. UU9.8-4P-TH-7.0-C-11-2S

PART NO. MATERIAL (BOBBIN) MATERIAL (TERMINAL) TERMINAL (PLATING) PIN ALLOCATION NOTE

TBI-223-01032.1106	PM-9630	CP WIRE	Sn	ALL PIN	S
					H

TOLERANCE: 0<L<=4:±0.1 4<L<=16:±0.2 16<L<=63:±0.3 UNIT : m / m SCALE 1 : 1

Finish: 1. PB wire Immersion Sn on terminal : Thickness:Sn plating,100%,5 μm (200 μ inches) min,Base nickel 0.625 μm (25 μ inches) min.
2. CP wire Immersion Sn on terminal : Thickness:Sn plating,100%,5 μm (200 μ inches) min.
3. Coplanarity deviation: 0.10 mm (0.004 inches) max.

REV 2