



**TRANSFORMER BOBBIN
INDUSTRIAL CO.,LTD.**

Tel : 86-769-88789999 Fax : 86-769-88789989
 http:// tbi-tw.com e-mail : tb6688@ms46.hinet.net

REVISIONS

REV	SYM	DRAFTER	CHECKER	DATE
①		H.X.DUAN	G.F.YANG	08/11/11
②		H.X.DUAN	G.F.YANG	09/02/11
③				

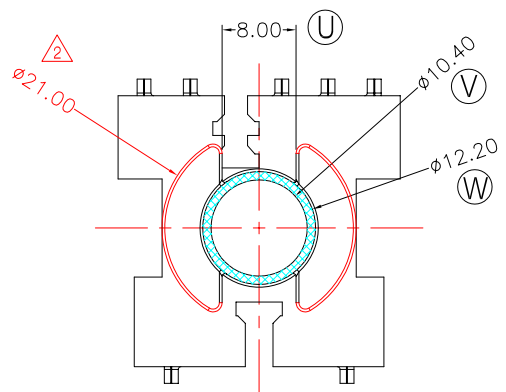
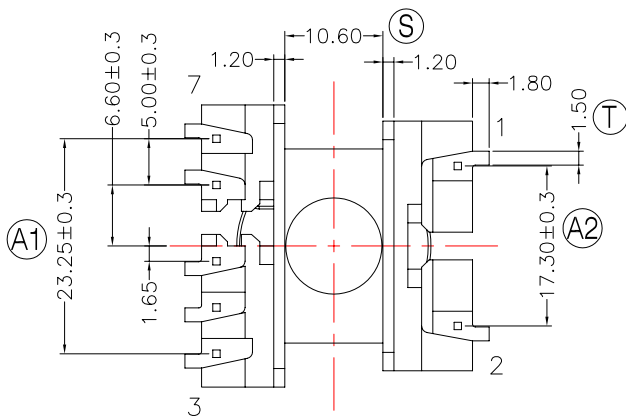
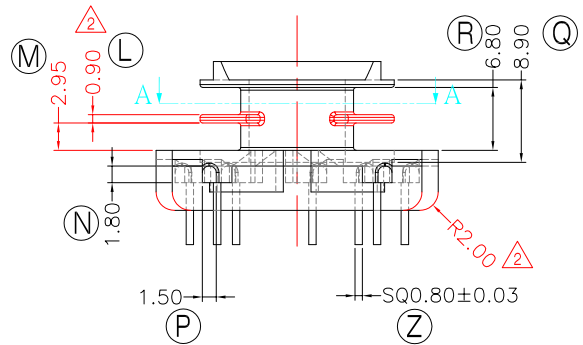
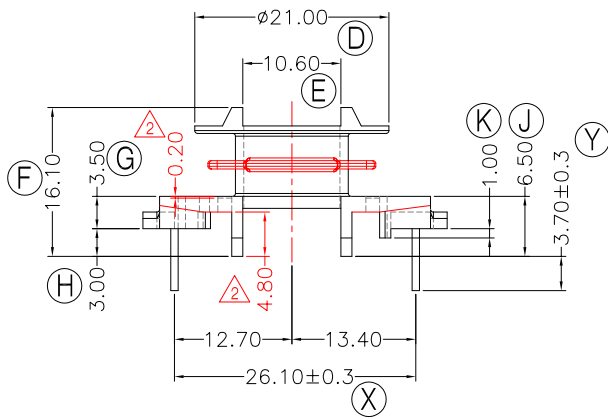
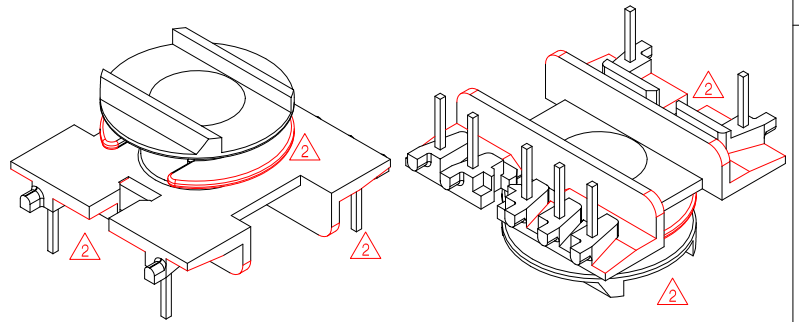
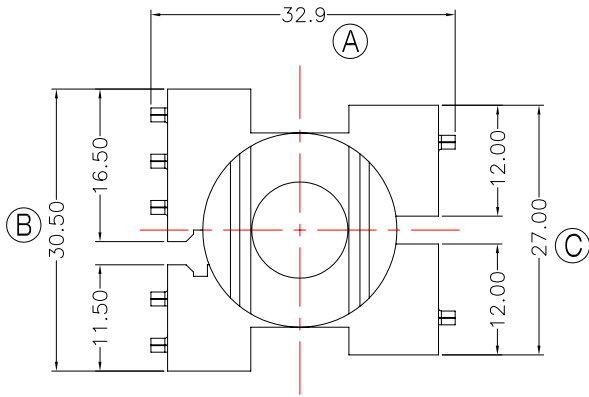

Section A-A

1. 焊錫前拉力: 1.0KG MIN, 焊錫後拉力: 1.5KG MIN;

DWG NO. EER30-V-7P-TH-D-12-2S

PART NO. MATERIAL (BOBBIN) MATERIAL (TERMINAL) TERMINAL (PLATING) PIN ALLOCATION NOTE

TBI-204-03042.1206 PM-9820 CP WIRE Sn ALL PIN S

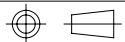

TOLERANCE: ±0.2

UNIT : m / m

SCALE 1 : 1

Finish: 1. PB wire Immersion Sn on terminal : Thickness: Sn plating, 100,5 μm (200 μ inches) min, Base nickel 0.625 μm (25 μ inches) min.
 2. CP wire Immersion Sn on terminal : Thickness: Sn plating, 100,5 μm (200 μ inches) min.
 3. Coplanarity deviation: 0.10 mm (0.004 inches) max.

REV 2