



**TRANSFORMER BOBBIN
INDUSTRIAL CO.,LTD.**

Tel : 86-769-88789999 Fax : 86-769-88789989
http:// tbi-tw.com e-mail : tb6688@ms46.hinet.net

REVISIONS

REV	SYM	DRAFTER	CHECKER	DATE
1		X.H.GU	G.F.YANG	10/12/11
2		X.H.GU	G.F.YANG	12/12/11
3		X.H.GU	G.F.YANG	03/13/12

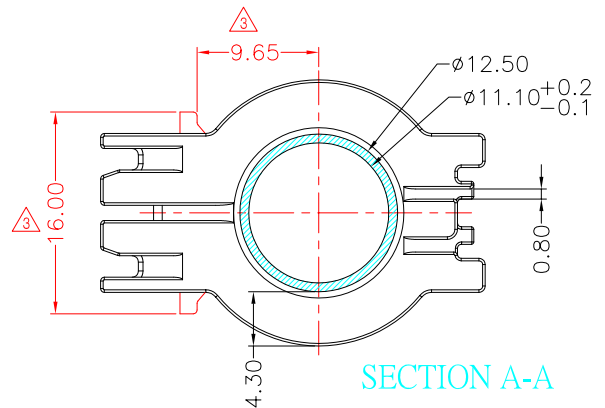
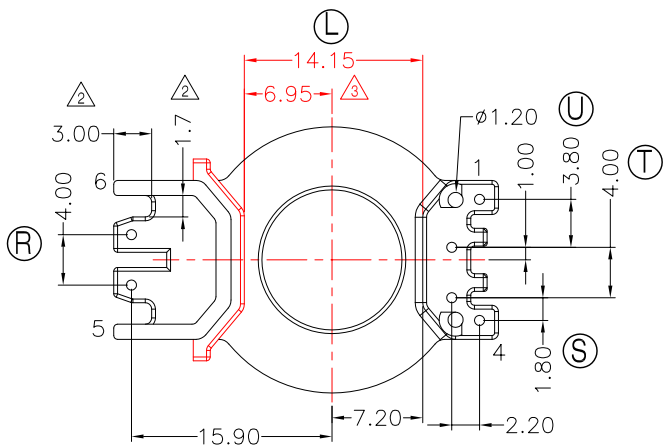
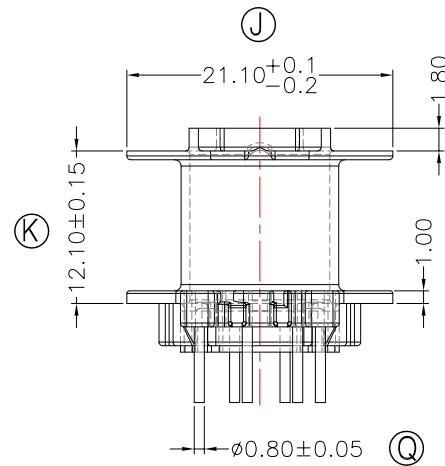
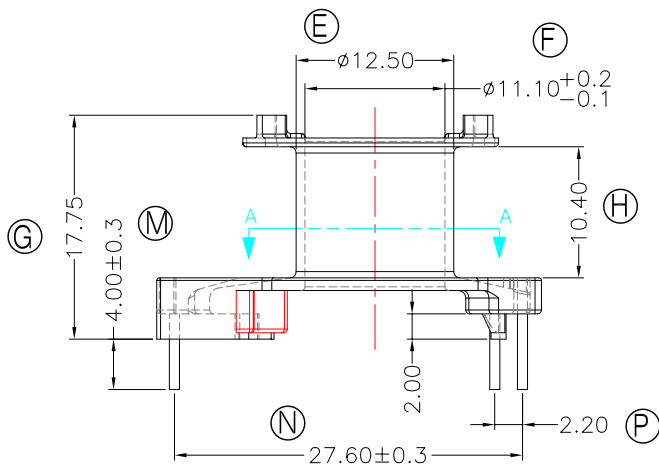
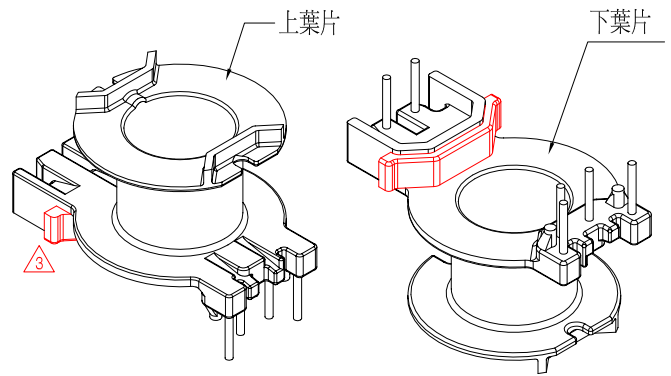
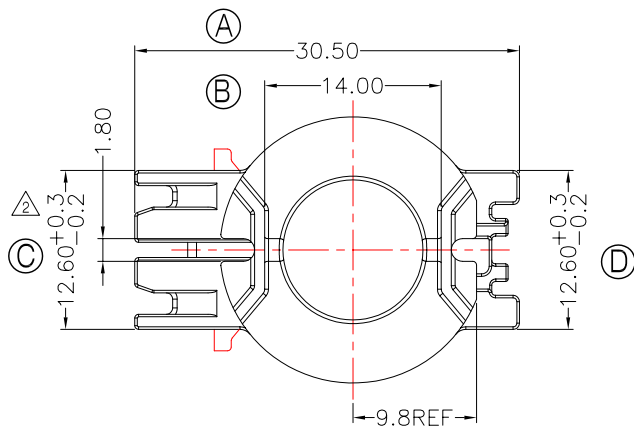

NOTE:

1. 焊錫前拉力 : 1.0Kg Min, 焊錫後拉力 : 1.5Kg Min.
2. 強度任意一點3.0Kg Min. 以下測試點除外(上下葉片強度任意一點1.0Kg Min)
3. PIN來回折彎90度3次不斷.

DWG NO.	RM10-18.6-6P-TH-C7-12				
PART NO.	MATERIAL (BOBBIN)	MATERIAL (TERMINAL)	TERMINAL (PLATING)	PIN ALLOCATION	NOTE
TBI-208-04371.1206	PM-9820(BK)	CP WIRE	Sn	ALL PIN	S
TOLERANCE: 0<L<=4:±0.1 4<L<=16:±0.2 16<L<=63:±0.3					
				UNIT : m / m	SCALE 1 : 1

Finish: 1. PB wire Immersion Sn on terminal : Thickness:Sn plating,100,5 μm (200 μ inches) min,Base nickel 0.625 μm (25 μ inches) min.
2. CP wire Immersion Sn on terminal : Thickness:Sn plating,100,5 μm (200 μ inches) min.
3. Coplanarity deviation: 0.10 mm (0.004 inches) max.

REV 3