



TRANSFORMER BOBBIN INDUSTRIAL CO.,LTD.

Tel : 86-769-88789999 Fax : 86-769-88789999
 http:// tbi-tw.com e-mail : tb6688@ms46.hinet.net

REVISIONS

REV	SYM	DRAFTER	CHECKER	DATE
3		X.X.YUAN	G.F.YANG	02/03/12
4		X.H.GU	G.F.YANG	04/07/12
5		X.H.GU	G.F.YANG	07/09/12

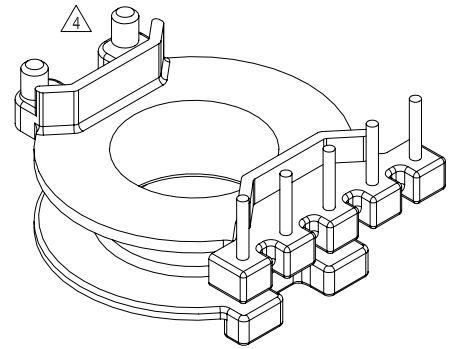
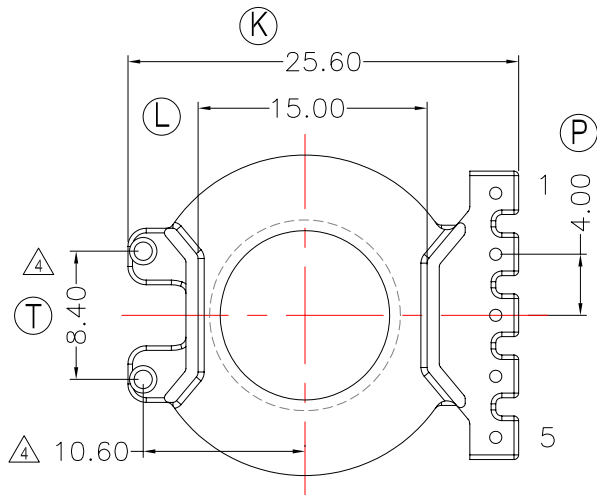
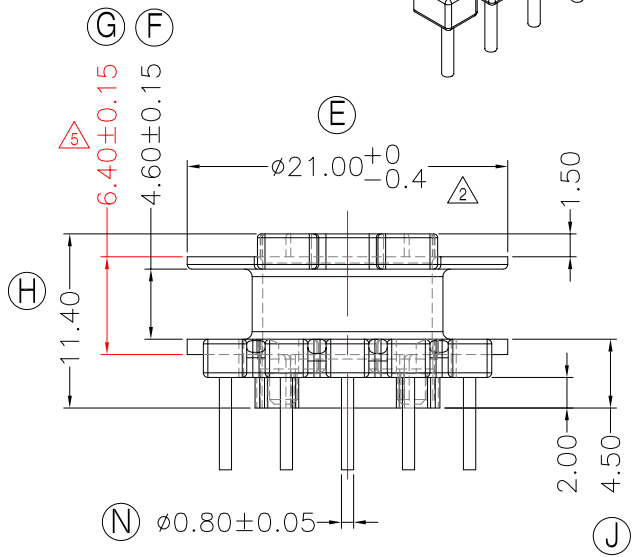
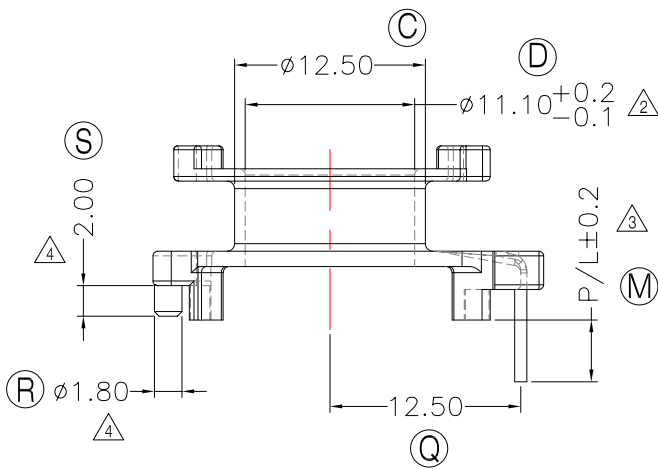
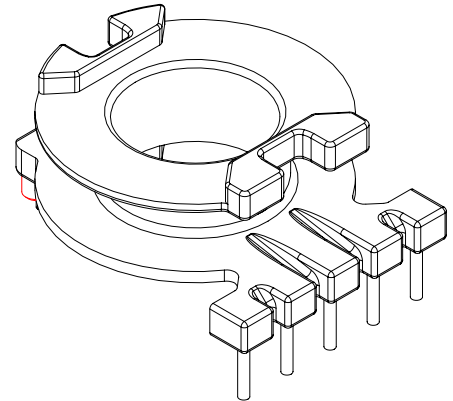
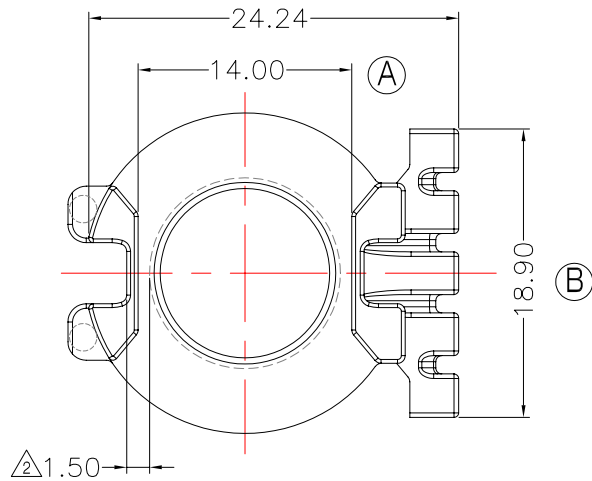

NOTE:

1. 任一點的強度為1.8kgMIN
2. 焊前拉力:1.0kg Min; 焊後拉力1.5kg Min

DWG NO. RM10-12.9G-5P-TH-C0-12

PART NO.	MATERIAL (BOBBIN)	MATERIAL (TERMINAL)	TERMINAL (PLATING)	PIN ALLOCATION	NOTE
TBI-208-04301.1206	PM-9820	CP WIRE	Sn	ALL PIN P/L=2.7±0.2	S
TBI-208-04301.1216	PM-9820	CP WIRE	Sn	ALL PIN P/L=4.5±0.2	暫無刀模 H
TBI-208-04301.1226	PM-9820	CP WIRE	Sn	ALL PIN P/L=5.0±0.2	

TOLERANCE: 0<L<=4:±0.1 4<L<=16:±0.2 16<L<=63:±0.3

UNIT : m / m

SCALE 1 : 1

Finish: 1. PB wire Immersion Sn on terminal : Thickness:Sn plating,100,5 μm (200 μ inches) min,Base nickel 0.625 μm (25 μ inches) min.
 2. CP wire Immersion Sn on terminal : Thickness:Sn plating,100,5 μm (200 μ inches) min.
 3. Coplanarity deviation: 0.10 mm (0.004 inches) max.

REV 5