



TRANSFORMER BOBBIN INDUSTRIAL CO.,LTD.

Tel : 86-769-88789999 Fax : 86-769-88789989
 http:// tbi-tw.com e-mail : tb6688@ms46.hinet.net

REVISIONS

REV	SYM	DRAFTER	CHECKER	DATE
②		T.S.LII	W.H.HSU	06/02/03
③		T.S.LII	W.H.HSU	07/21/06
④		T.S.LII	W.H.HSU	08/04/06

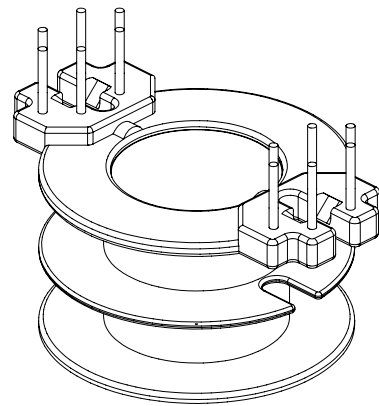
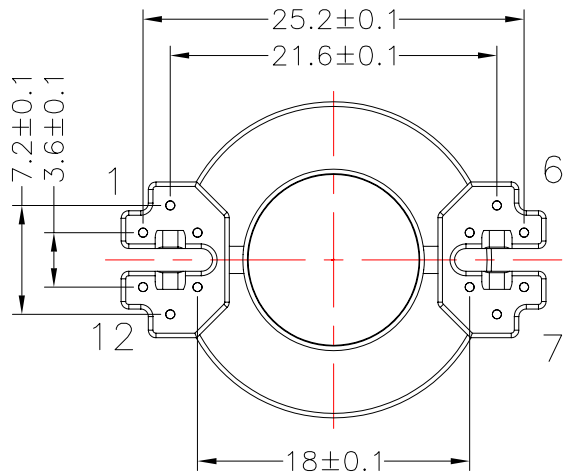
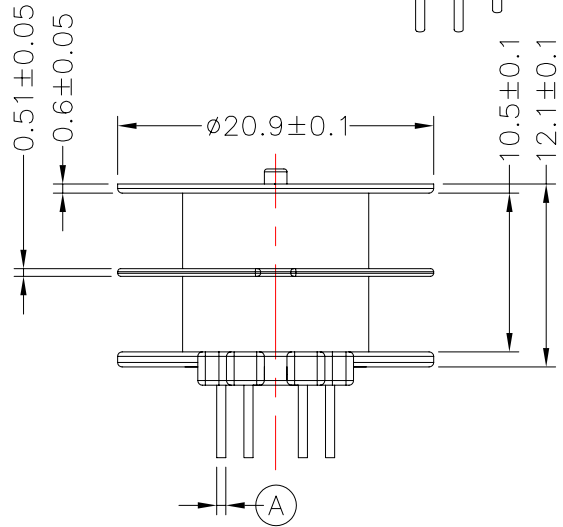
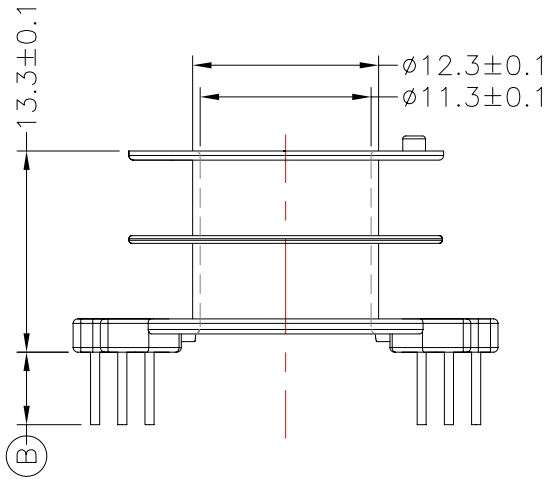
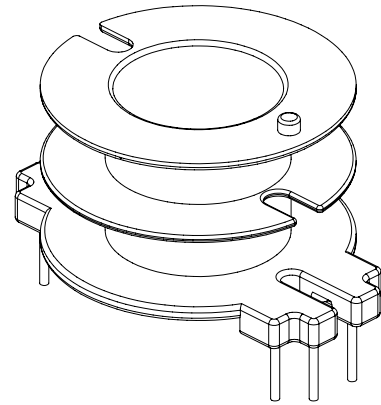
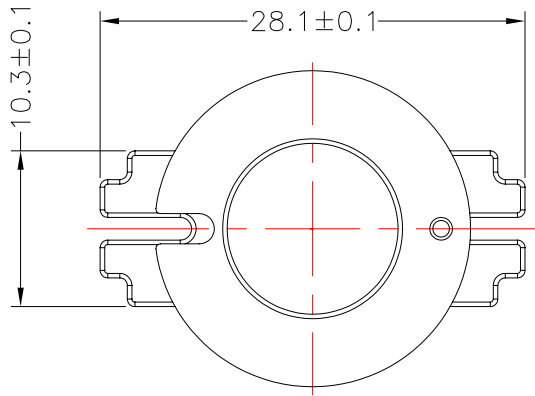

DWG NO.	RM10-12P-TH-B-1-2S				
PART NO.	MATERIAL (BOBBIN)	MATERIAL (TERMINAL)	TERMINAL (PLATING)	PIN ALLOCATION	NOTE
TBI-208-04022.106	PM-9630	CP WIRE	Sn	ALL PIN , (A)=SQ0.5 (B)=4.8±0.3	
TBI-208-04022.116	PM-9630	CP WIRE	Sn	ALL PIN , (A)= ϕ 0.6 (B)=4.8±0.3	
④ TBI-208-04022.126	PM-9630	CP WIRE	Sn	CUT PIN 2,5,8,11 (A)= ϕ 0.6 (B)=4.8±0.3	
④ TBI-208-04022.136	PM-9630	CP WIRE	Sn	ALL PIN , (A)= ϕ 0.6 (B)=7.0±0.3	
TOLERANCE: .X±0.15 .XX±0.10 .XXX±0.05 UNIT : m / m SCALE 3 : 1					
Finish: 1. PB wire Immersion Sn on terminal : Thickness:Sn plating,100,5 μ m (200 μ inches) min,Base nickel 1~2.54um (39~100u inches) min. 2. CP wire Immersion Sn on terminal : Thickness:Sn plating,100,5 μ m (200 μ inches) min. 3. Coplanarity deviation: 0.10 mm (0.004 inches) max.					REV 4