

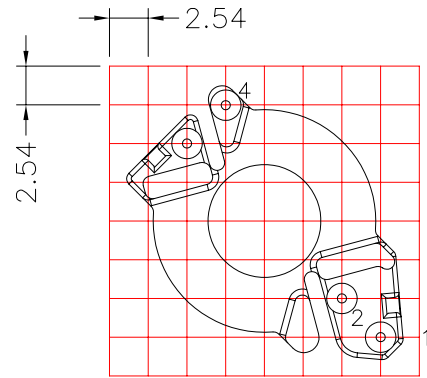

**TRANSFORMER BOBBIN
INDUSTRIAL CO.,LTD.**

Tel : 86-769-88789999 Fax : 86-769-88789989
 http:// tbi-tw.com e-mail : tb6688@ms46.hinet.net

REVISIONS				
REV	SYM	DRAFTER	CHECKER	DATE
①		X.H.GU	G.F.YANG	12/19/07
②		G.F.YANG	W.H.HSU	11/19/08
③		G.F.YANG	W.H.HSU	12/18/08

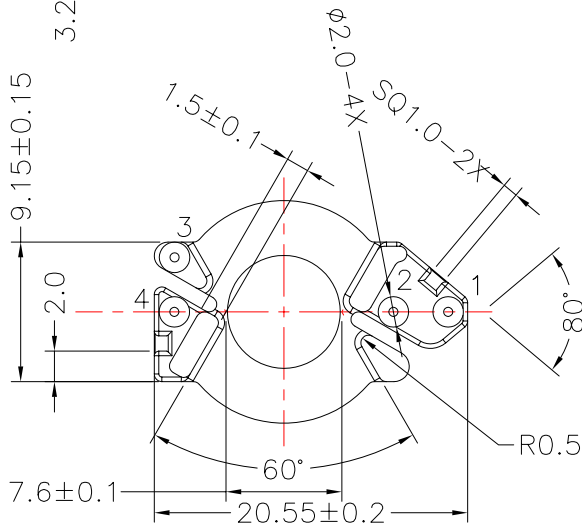
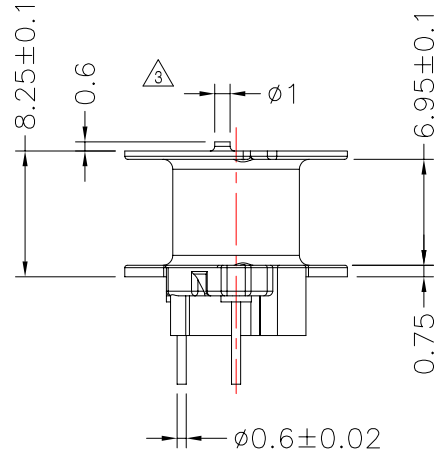
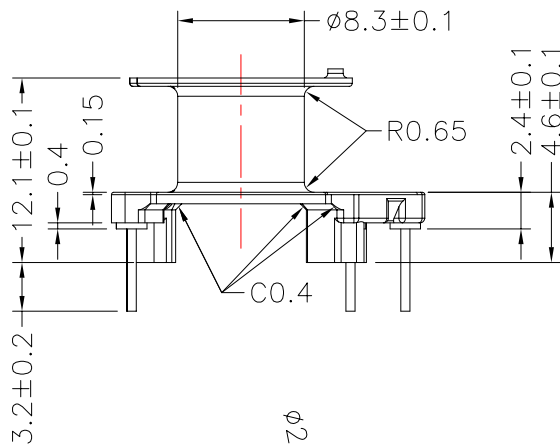
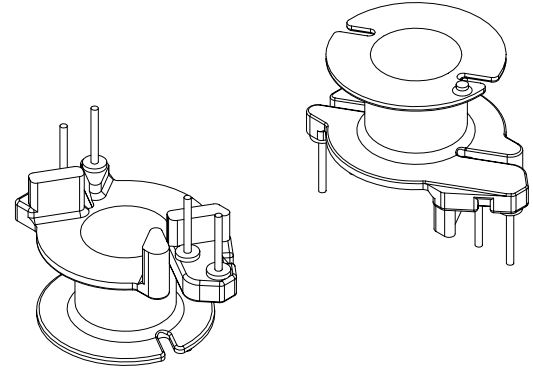
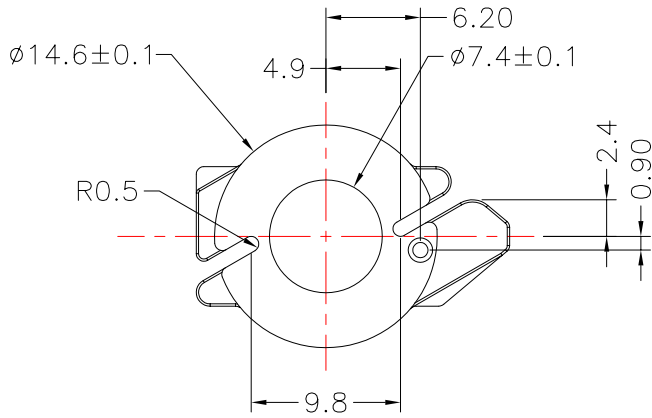

DWG NO.	RM7-4P-TH-B-12				
PART NO.	MATERIAL (BOBBIN)	MATERIAL (TERMINAL)	TERMINAL (PLATING)	PIN ALLOCATION	NOTE
TBI-208-09021.1206	PM-9820	C.P WIRE	Sn	ALL PIN	
TBI-208-09021.1216	PM-9820	C.P WIRE	Sn	CUT PIN #1	

	TOLERANCE	X.X	X.XX	UNIT : m/m	SCALE 2:1	
		0~10	±0.2			±0.08
		10~20	±0.3			±0.15
	> 20	±0.5	±0.25			

Finish: 1. Pb wire Immersion Sn on terminal : Thickness:Sn plating,100,5 μm (200 μ inches) min,Base nickel 0.625 μm (25 μ inches) min.
 2. CP wire Immersion Sn on terminal : Thickness:Sn plating,100,5 μm (200 μ inches) min.
 3. Coplanarity deviation: 0.10 mm (0.004 inches) max.

REV 3