

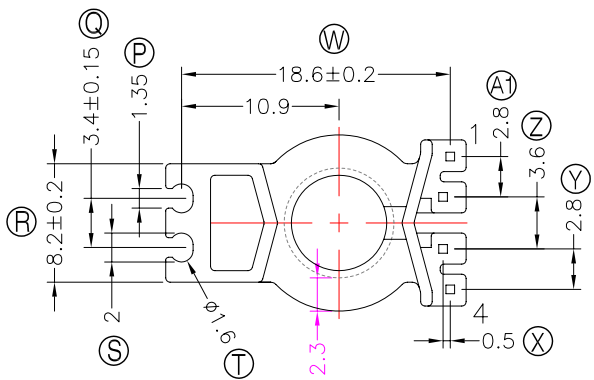

TRANSFORMER BOBBIN
INDUSTRIAL CO.,LTD.

Tel : 86-769-88789999 Fax : 86-769-88789989
http:// tbi-tw.com e-mail : tb6688@ms46.hinet.net

REVISIONS				
REV	SYM	DRAFTER	CHECKER	DATE
△1		X.H.GU	G.F.YANG	05/23/16
△2				
△3				

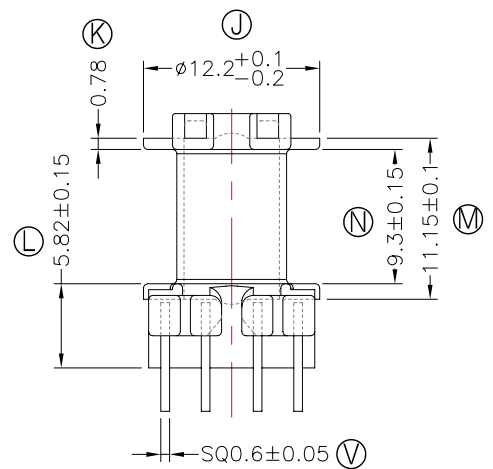
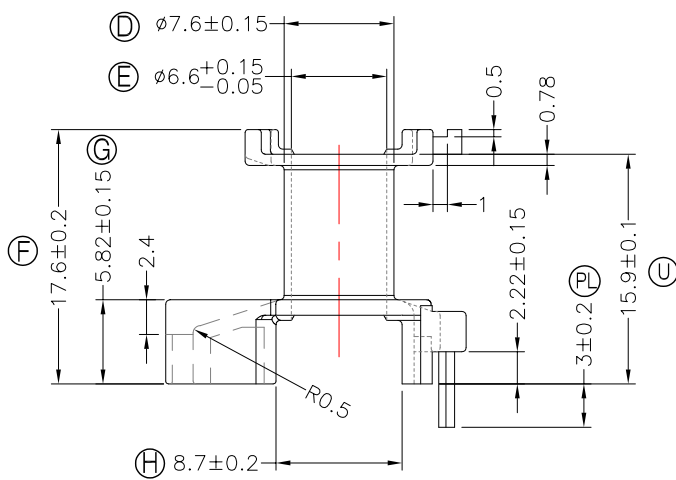
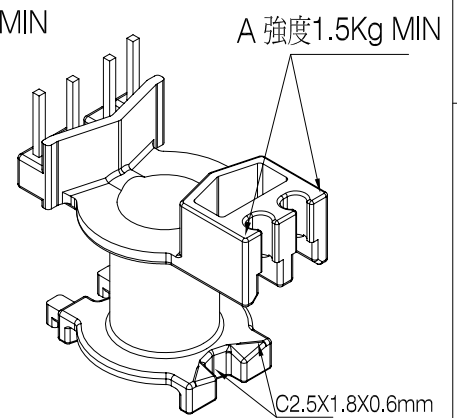
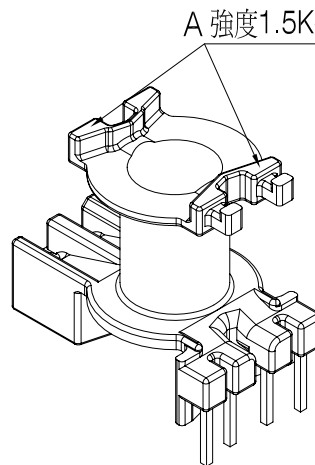
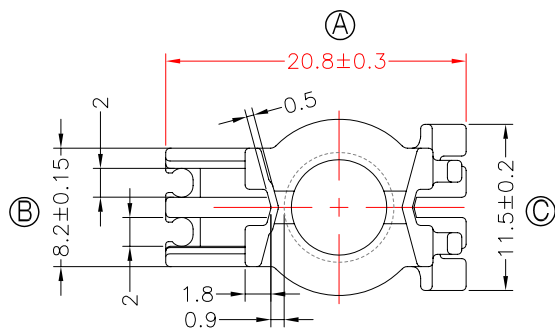

NOTE:

- 1.耐壓4.0Kv /1.5mA 60S;
- 2.焊錫溫度:450°±10° 3SEC;
- 3.焊錫前拉力:1.0KG MIN,焊錫後拉力:1.5KG MIN;
- 4.任意一點強度須1.8kg MIN;(除以下測試點.A處為1.5kg MIN).
- 5.WINDING SPACE: 9.3mm*2.3mm=21.39mm²

DWG NO. RM6-15.7G-4P-TH-B3-11

PART NO.	MATERIAL (BOBBIN)	MATERIAL (TERMINAL)	TERMINAL (PLATING)	PIN ALLOCATION	NOTE
TBI-208-02231.1106	PM-9630	CP WIRE	Sn	ALL PIN	S

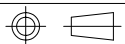

TOLERANCE: 0<L<=4:±0.1 4<L<=16:±0.2 16<L<=63:±0.3

UNIT : m / m

SCALE 1 : 1

Finish: 1. PB wire Immersion Sn on terminal : Thickness:Sn plating,100%,5 μm (200 μ inches) min,Base nickel 0.625 μm (25 μ inches) min.
2. CP wire Immersion Sn on terminal : Thickness:Sn plating,100%,5 μm (200 μ inches) min.
3. Coplanarity deviation: 0.10 mm (0.004 inches) max.

REV 1