



TRANSFORMER BOBBIN
INDUSTRIAL CO.,LTD.

Tel : 86-769-88789999 Fax : 86-769-88789989
http:// tbi-tw.com e-mail : tb6688@ms46.hinet.net

REVISIONS

REV	SYM	DRAFTER	CHECKER	DATE
△4		T.S.LII	W.H.HSU	07/21/06
△5		T.S.LII	W.H.HSU	02/27/07
△6		T.S.LII	W.H.HSU	02/20/08

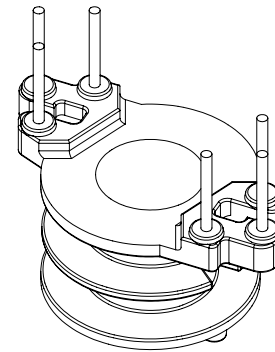
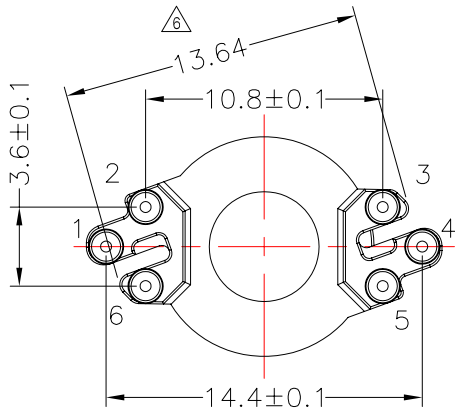
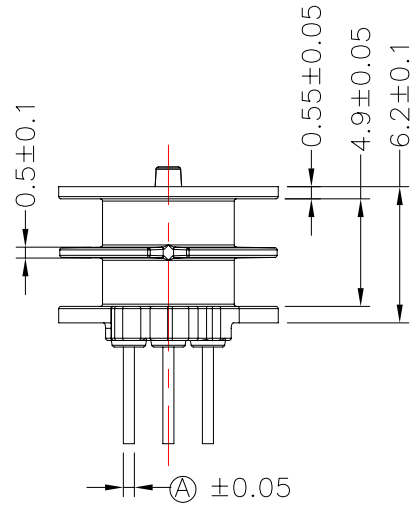
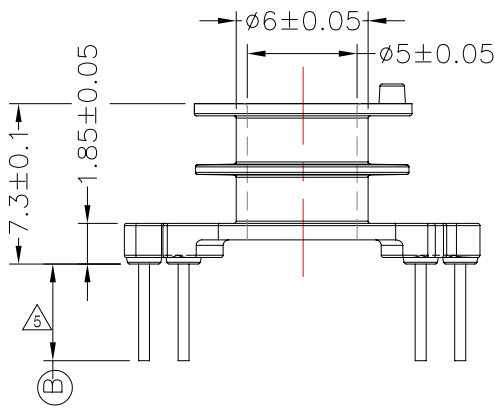
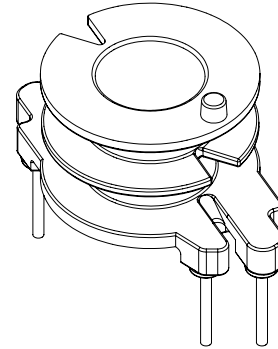
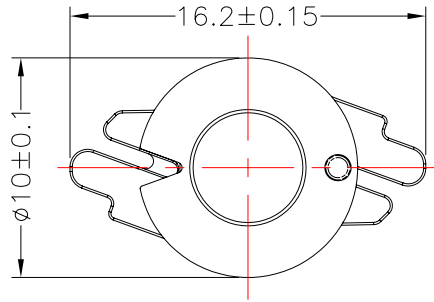

DWG NO. RM5-6P-TH-B-1-2S

PART NO.	MATERIAL (BOBBIN)	MATERIAL (TERMINAL)	TERMINAL (PLATING)	PIN ALLOCATION	NOTE
TBI-208-03022.106	PM-9630	CP WIRE	Sn	ALL PIN , (A) =SQ0.4 ,(B)= 4.4±0.3	
TBI-208-03022.116	PM-9630	CP WIRE	Sn	Pin cut # 1,4 (A) =SQ0.4 ,(B)= 4.4±0.3	H
TBI-208-03022.126	PM-9630	CP WIRE	Sn	ALL PIN , (A) =Ø0.5 ,(B)= 4.5±0.2	
TBI-208-03022.136	PM-9630	CP WIRE	Sn	Pin cut # 1,4 (A) =Ø0.5 ,(B)= 4.4±0.3	
TBI-208-03022.146	PM-9630	CP WIRE	Sn	Pin cut # 4 (A) =Ø0.5 ,(B)= 4.4±0.3	
△TBI-208-03022.156	PM-9630	CP WIRE	Sn	ALL PIN , (A) =Ø0.5 ,(B)= 5.0±0.3	
△TBI-208-03022.166	PM-9630	CP WIRE	Sn	ALL PIN , (A) =Ø0.5 ,(B)=2.7±0.2	
△TBI-208-03022.176	PM-9630	CP WIRE	Sn	ALL PIN , (A) =Ø0.5 ,(B)=4.7±0.2	
TBI-208-03022.186	PM-9630	CP WIRE	Sn	ALL PIN , (A) =Ø0.5 ,(B)=3.5±0.2	

TOLERANCE: .X±0.15 .XX±0.10 .XXX±0.05 UNIT : m / m SCALE 3 : 1

Finish: 1. PB wire Immersion Sn on terminal : Thickness:Sn plating,100,5µm (200µ inches) min,Base nickel 0.625µm (25µ inches) min.
2. CP wire Immersion Sn on terminal : Thickness:Sn plating,100,5µm (200µ inches) min.
3. Coplanarity deviation: 0.10mm (0.004 inches) max.

REV 6