

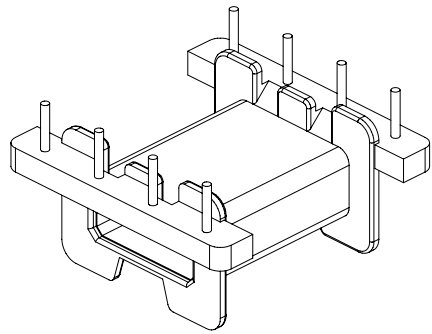

**TRANSFORMER BOBBIN INDUSTRIAL CO.,LTD.**

Tel : 86-769-88789999 Fax : 86-769-88789989  
 http:// tbi-tw.com e-mail : tb6688@ms46.hinet.net

REVISIONS				
REV	SYM	DRAFTER	CHECKER	DATE
①		YAN.TANG	G.F.YANG	06/02/10
②				
③				

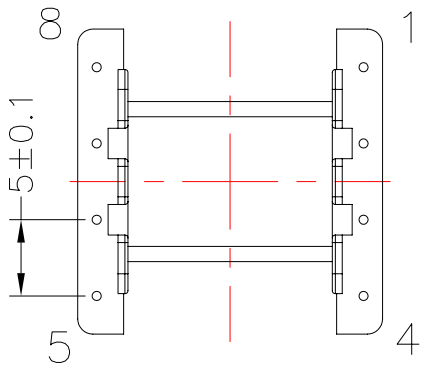
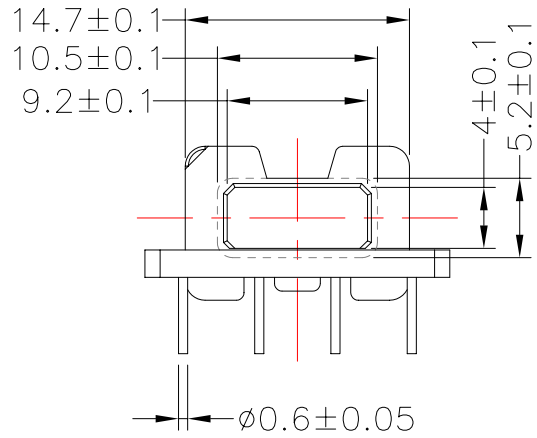
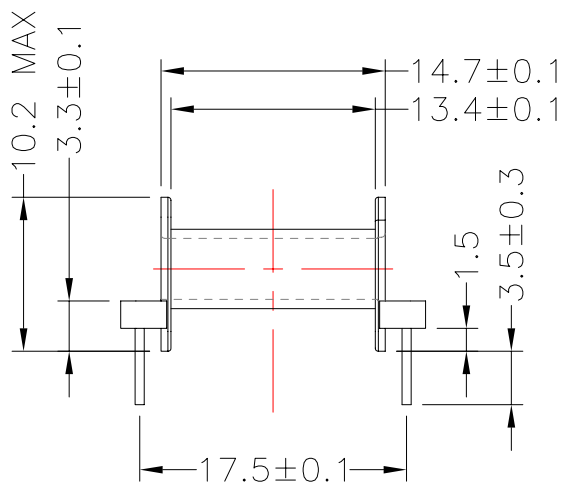
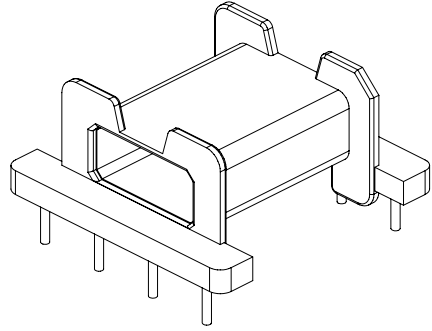
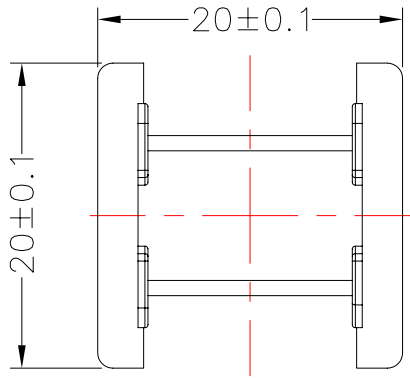

**DWG NO. EFD20-8P-TH-5.0-A-23**

PART NO.	MATERIAL (BOBBIN)	MATERIAL (TERMINAL)	TERMINAL (PLATING)	PIN ALLOCATION	NOTE
TBI-207-01011.2306	DAP D2102F	CP WIRE	Sn	ALL PIN	H

**TOLERANCE:** .X±0.15 .XX±0.10 .XXX±0.05
 **UNIT :** m / m
**SCALE** 2 : 1

**Finish:**  
 1. PB wire Immersion Sn on terminal : Thickness:Sn plating,100,5 μm (200 μ inches) min,Base nickel 0.625 μm (25 μ inches) min.  
 2. CP wire Immersion Sn on terminal : Thickness:Sn plating,100,5 μm (200 μ inches) min.  
 3. Coplanarity deviation: 0.10 mm (0.004 inches) max.

**REV 1**