



TRANSFORMER BOBBIN INDUSTRIAL CO.,LTD.

Tel : 86-769-88789999 Fax : 86-769-88789989
 http:// tbi-tw.com e-mail : tb6688@ms46.hinet.net

REVISIONS

REV	SYM	DRAFTER	CHECKER	DATE
△1		X.H.GU	G.F.YANG	11/23/15
△2		X.H.GU	G.F.YANG	12/23/15
△3		X.H.GU	G.F.YANG	03/31/16

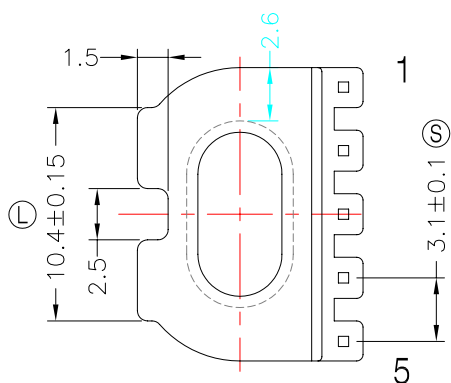
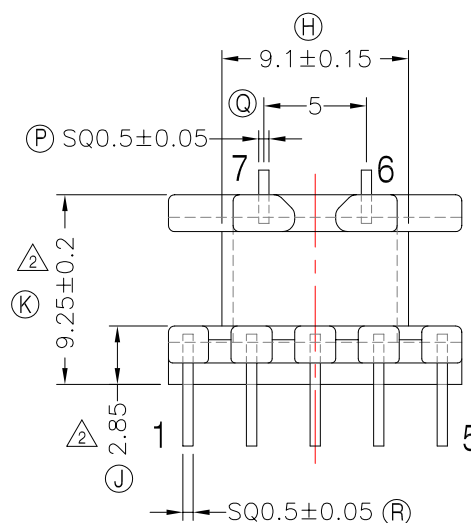
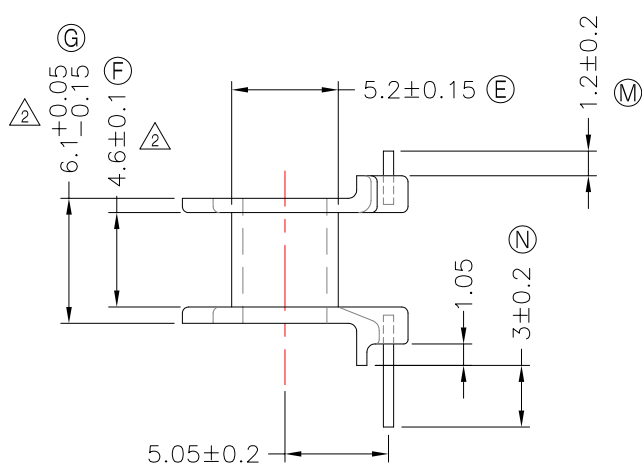
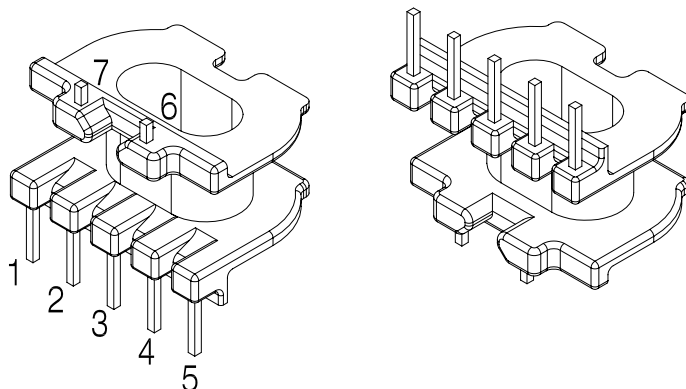
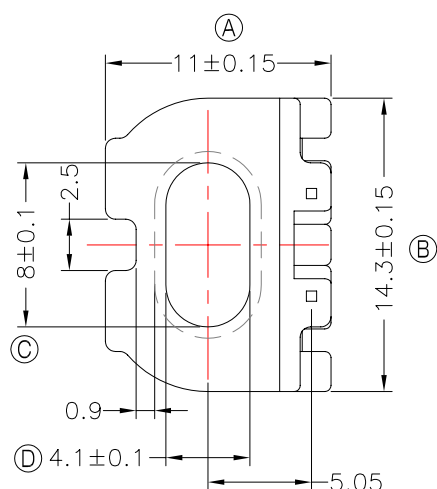

NOTE:

- 1.耐壓4.0Kv /1.5mA 60S;
- 2.焊錫溫度:450°±10° 3SEC;
- 3.任意一點強度須1.5kg MIN;
- 4.焊錫前拉力:1.0KG MIN,焊錫後拉力:1.5KG MIN;
- 5.WINDING SPACE: 4.6mm*2.6mm=11.96mm²

DWG NO.	EPC17-9.7-7P-TH-B5-17 △3				
PART NO.	MATERIAL (BOBBIN)	MATERIAL (TERMINAL)	TERMINAL (PLATING)	PIN ALLOCATION	NOTE
TBI-206-01251.1706	PM-9823 △3	CP WIRE	Sn	ALL PIN	S
TBI-206-01251.1716	PM-9823 △3	CP WIRE	Sn	CUT PIN#3	
	TOLERANCE:0<L<=4:±0.1 4<L<=16:±0.2 16<L<=63:±0.3			UNIT : m / m	SCALE 1 : 1
Finish:	1. PB wire Immersion Sn on terminal : Thickness:Sn plating,100%,5 μm (200 μ inches) min,Base nickel 0.625 μm (25 μ inches) min. 2. CP wire Immersion Sn on terminal : Thickness:Sn plating,100%,5 μm (200 μ inches) min. 3. Coplanarity deviation: 0.10 mm (0.004 inches) max.				REV 3