

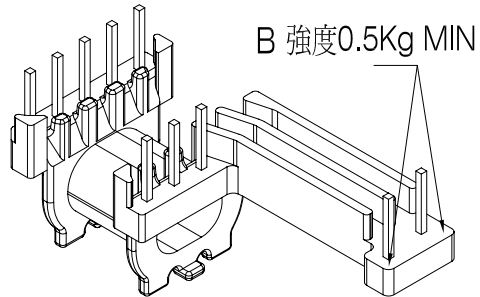

**TRANSFORMER BOBBIN
INDUSTRIAL CO., LTD.**

Tel : 86-769-88789999 Fax : 86-769-88789989
http:// tbi-tw.com e-mail : tb6688@ms46.hinet.net

REVISIONS				
REV	SYM	DRAFTER	CHECKER	DATE
1		M.WANG	G.F.YANG	08/10/16
2				
3				

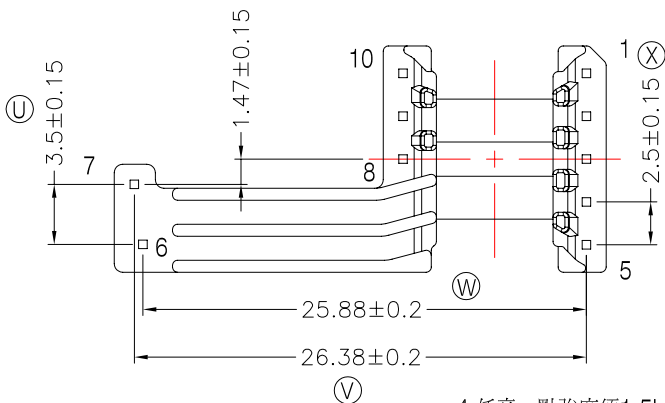
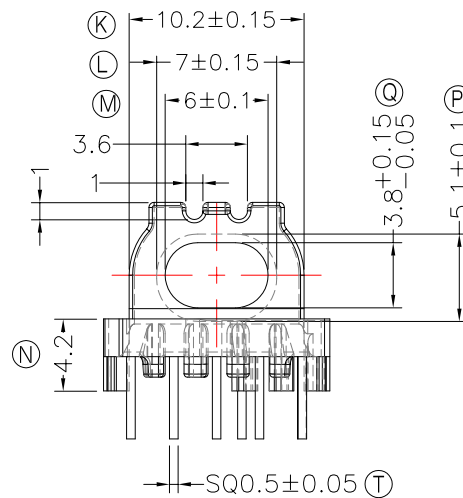
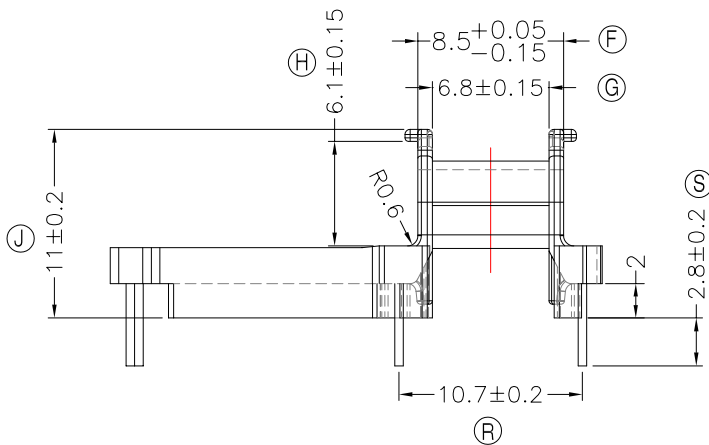
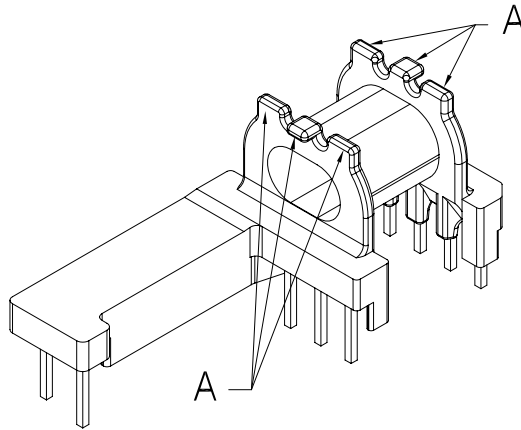
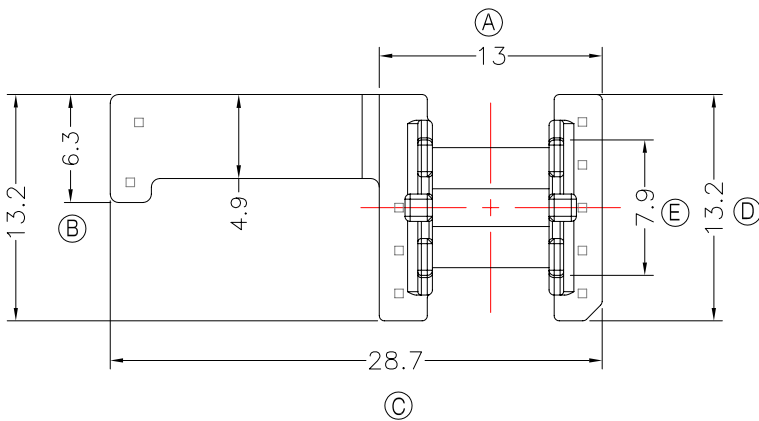

NOTE:

- 耐壓4.0Kv /1.5mA 60S;
- 焊錫溫度:450°±10° 3SEC
- 焊錫前拉力:1.0KG MIN,焊錫後拉力:1.5KG MIN;
- 任意一點強度須1.5kg MIN;(除以下測試點,A處爲1.0MIN,PIN長的一側, B爲0.5KG MIN).

DWG NO.	EPC13-13C-10P-TH-A4-17				
PART NO.	MATERIAL (BOBBIN)	MATERIAL (TERMINAL)	TERMINAL (PLATING)	PIN ALLOCATION	NOTE
TBI-206-04141.1706	PM-9823	CP WIRE	Sn	ALL PIN	S
TBI-206-04141.1716	PM-9823	CP WIRE	Sn	NO PIN#8,9,10	

	TOLERANCE: 0<L<=4:±0.1 4<L<=16:±0.2 16<L<=63:±0.3	UNIT : m / m	SCALE 1 : 1
--	---	--------------	-------------

Finish: 1. PB wire Immersion Sn on terminal : Thickness:Sn plating,100%,5 μm (200 μinches) min,Base nickel 0.625 μm (25 μ inches) min.
2. CP wire Immersion Sn on terminal : Thickness:Sn plating,100%,5 μm (200 μinches) min.
3. Coplanarity deviation: 0.10 mm (0.004 inches)max.

REV	1
-----	---