



TRANSFORMER BOBBIN  
INDUSTRIAL CO.,LTD.

Tel : 86-769-88789999 Fax : 86-769-88789989  
http:// tbi-tw.com e-mail : tb6688@ms46.hinet.net

REVISIONS

REV	SYM	DRAFTER	CHECKER	DATE
3		F.LU	G.F.YANG	09/24/13
4		X.H.GU	G.F.YANG	10/22/15
5		X.H.GU	G.F.YANG	11/26/15

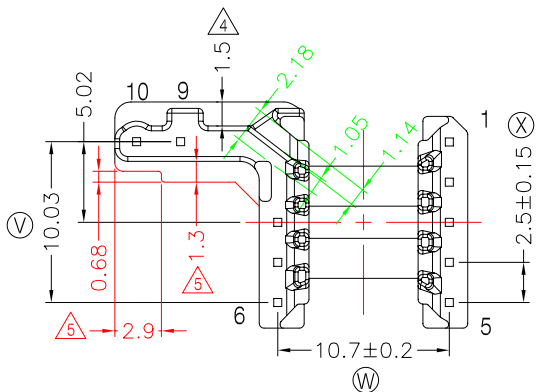
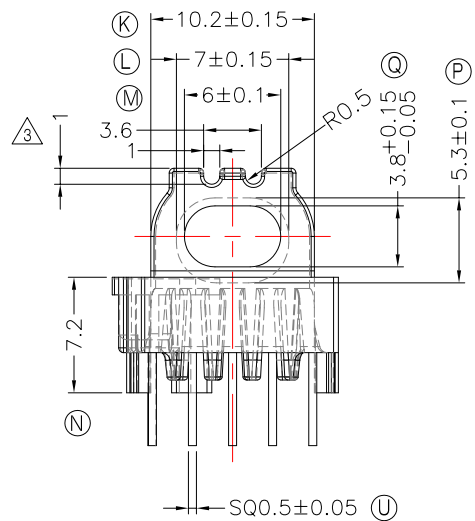
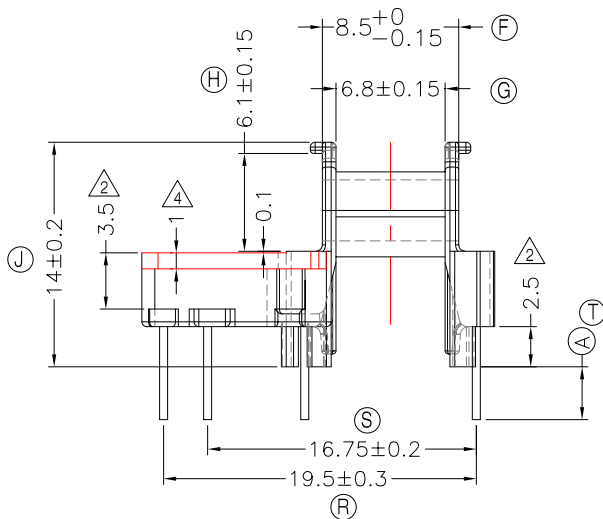
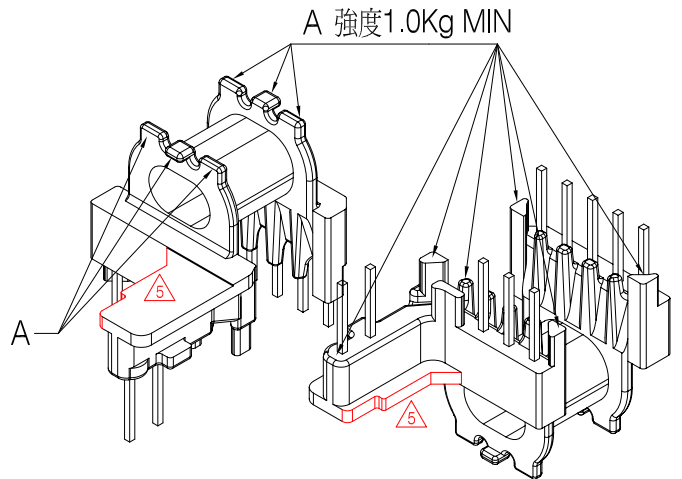
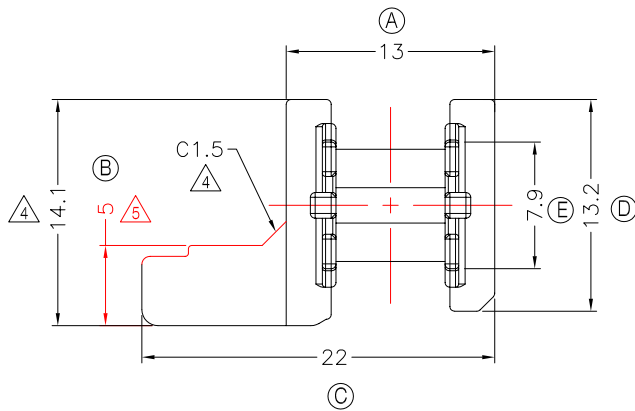

NOTE:

1. 焊錫前拉力:1.0KG MIN, 焊錫後拉力:1.5KG MIN;
2. 任意一點強度須1.5kg MIN;(除以下測試點.A.處為1.0MIN).
3. 耐壓4.0Kv /1.5mA 60S;
4. 焊錫溫度:450°±10° 3SEC

DWG NO. EPC13-13C-10P-TH-J-12

PART NO.	MATERIAL (BOBBIN)	MATERIAL (TERMINAL)	TERMINAL (PLATING)	PIN ALLOCATION	NOTE
TBI-206-04091.1206	PM-9820	CP WIRE	Sn	ALL PIN (A)=3.3±0.2	暫無刀模 S
TBI-206-04091.1216	PM-9820	CP WIRE	Sn	NO PIN#3,8 (A)=3.3±0.2	H
TBI-206-04091.1226	PM-9820	CP WIRE	Sn	ALL PIN (A)=2.8±0.2	
TBI-206-04091.1236	PM-9820	CP WIRE	Sn	NO PIN#3,8 (A)=2.8±0.2	

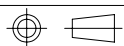

TOLERANCE: 0<L<=4:±0.1 4<L<=16:±0.2 16<L<=63:±0.3

UNIT : m / m

SCALE 1 : 1

Finish: 1. PB wire Immersion Sn on terminal : Thickness:Sn plating,100,5 μm (200 μ inches) min,Base nickel 0.625 μm (25 μ inches) min.  
2. CP wire Immersion Sn on terminal : Thickness:Sn plating,100,5 μm (200 μ inches) min.  
3. Coplanarity deviation: 0.10 mm (0.004 inches) max.

REV 5