



TRANSFORMER BOBBIN
INDUSTRIAL CO.,LTD.

Tel : 86-769-88789999 Fax : 86-769-88789989
http:// tbi-tw.com e-mail : tb6688@ms46.hinet.net

REVISIONS

| REV | SYM | DRAFTER | CHECKER | DATE |
|-----|-----|---------|----------|----------|
| ① | | X.H.GU | G.F.YANG | 01/14/10 |
| ② | | X.H.GU | G.F.YANG | 01/17/11 |
| ③ | | | | |

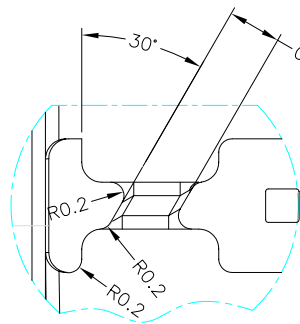

Detail Z (4:1)

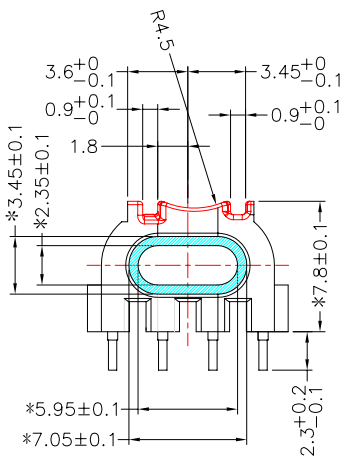
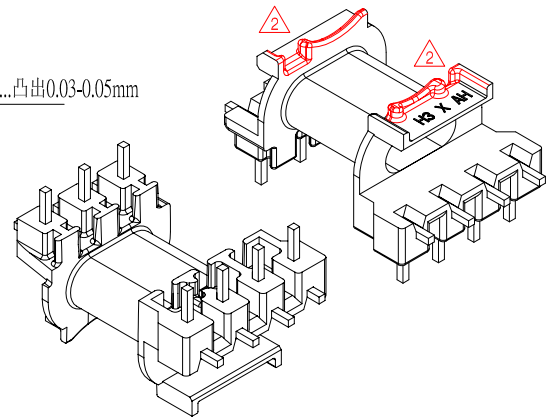
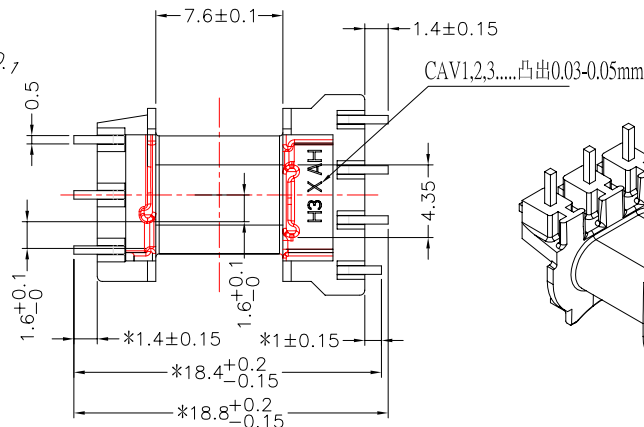

Section B-B

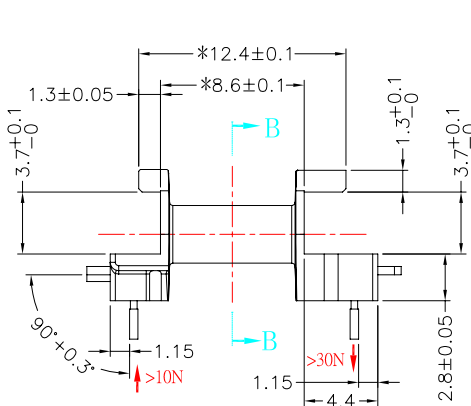

Section A-A

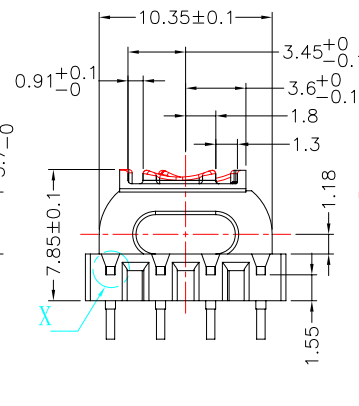

Detail X (4:1)

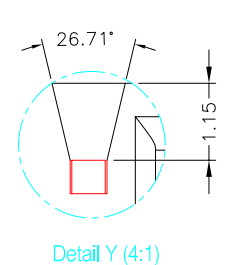

Detail Y (4:1)

技術要求:

1. 塑膠材質: SEE TABLE;
2. 防火等級: 94V-0;
3. 五金材質: CP線0.5*0.5mm(22%銅,78%鋼), 鍍錫100%,厚度0.003-0.005mm;
4. 產品最小壁厚為0.4mm;
5. 未注R做R0.2mm;
6. 推力大於10N, 拉力大於30N;
7. 產品不可有縮水、毛邊、繞線管區域表面不可有利角, 轉角處須平滑過渡;
8. 產品表面為光面;
9. 帶"*" 為重點尺寸。

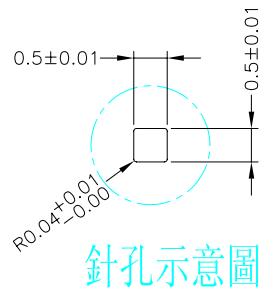

針孔示意圖

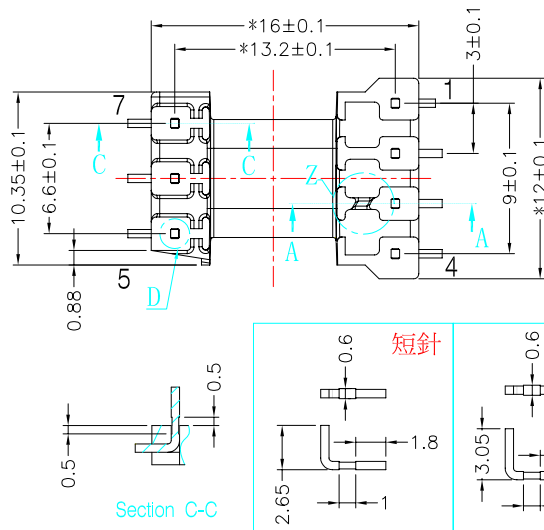

Section C-C

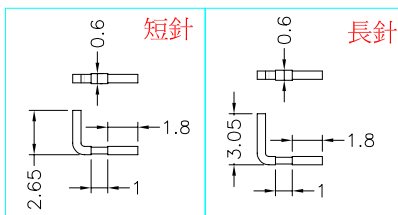

| | | | | | | | | | |
|--------------------|---------------------|---------------------|--------------------|----------------|-------|-------|-------|--------------|-------------|
| DWG NO. | EPC13-7P-THL-B-31 | | | | | | | | |
| PART NO. | MATERIAL (BOBBIN) | MATERIAL (TERMINAL) | TERMINAL (PLATING) | PIN ALLOCATION | NOTE | | | | |
| TBI-206-04021.3106 | LCP-E4008 (BK) (無齒) | CP WIRE | Sn | ALL PIN | H | | | | |
| GENERAL TOLERANCES | | | | | | | | | |
| | 0~1 | 1~3 | 3~6 | 6~10 | 10~15 | 15~22 | 22~30 | UNIT : m / m | SCALE 1 : 1 |
| | ±0.08 | ±0.09 | ±0.10 | ±0.11 | ±0.13 | ±0.15 | ±0.17 | | |

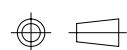

Finish: 1. PB wire Immersion Sn on terminal : Thickness:Sn plating,100,5 μm (200 μ inches) min,Base nickel 0.625 μm (25 μ inches) min.
2. CP wire Immersion Sn on terminal : Thickness:Sn plating,100,5 μm (200 μ inches) min.
3. Coplanarity deviation: 0.10 mm (0.004 inches) max.

REV 2