



TRANSFORMER BOBBIN INDUSTRIAL CO.,LTD.

Tel : 86-769-88789999 Fax : 86-769-88789989
 http:// tbi-tw.com e-mail : tb6688@ms46.hinet.net

REVISIONS

REV	SYM	DRAFTER	CHECKER	DATE
①		Y.G.HSU	W.H.HSU	01/11/07
②		S.Y.TANG	W.H.HSU	07/07/07
③				

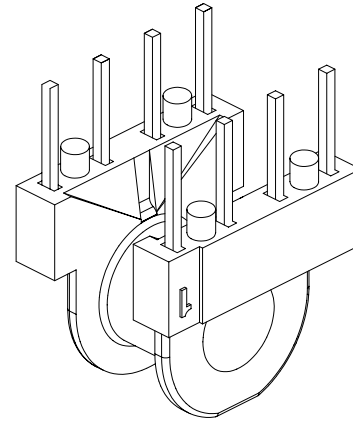
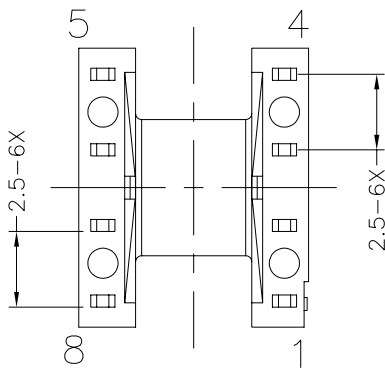
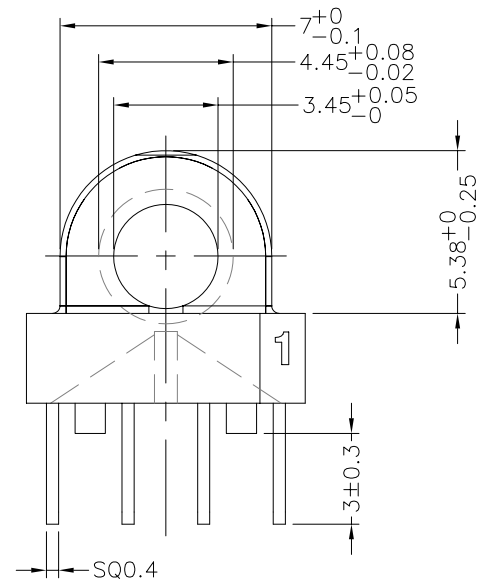
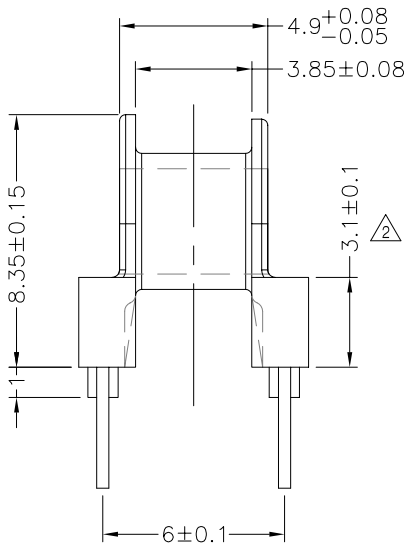
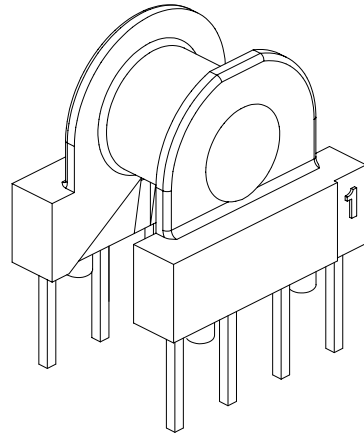
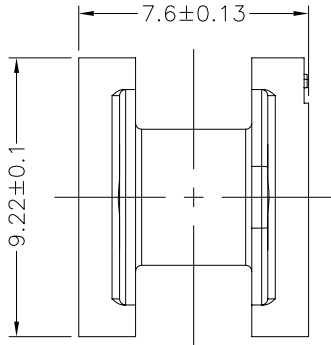

DWG NO.	EP7-8P-TH-2.5-H-1				
PART NO.	MATERIAL (BOBBIN)	MATERIAL (TERMINAL)	TERMINAL (PLATING)	PIN ALLOCATION	NOTE
TBI-203-08081.106	PM-9630	C,P WIRE	Sn	ALL PIN	
TBI-203-08081.116	PM-9630	C,P WIRE	Sn	CUT PIN #1,4,5,8	

TOLERANCE: .X±0.15 .XX±0.10 .XXX±0.05 UNIT : m / m SCALE 4 : 1

Finish: 1. Immersion gold on terminal : Thickness gold 0.075 μm (3 μ inches) min, Base nickel 0.625 μm (25 μ inches) min.
 2. Immersion Sn on terminal : Terminal:Sn plating,100, 5 μm (200 μ inches) min , Base nickel 0.625 μm (25 μ inches) min.
 3. Coplanarity deviation: 0.10 mm (0.004 inches) max.

REV 2