



TRANSFORMER BOBBIN INDUSTRIAL CO.,LTD.

Tel : 86-769-88789999 Fax : 86-769-88789989
 http:// tbi-tw.com e-mail : tb6688@ms46.hinet.net

REVISIONS

REV	SYM	DRAFTER	CHECKER	DATE
1		S.Y.TANG	G.F.YANG	11/24/07
2				
3				

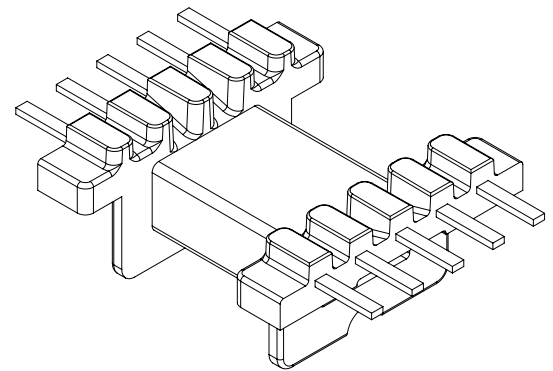
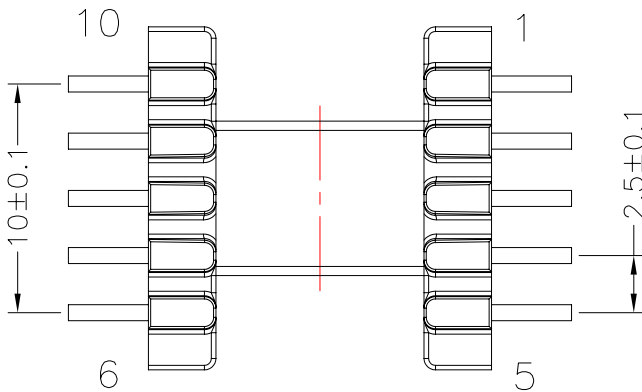
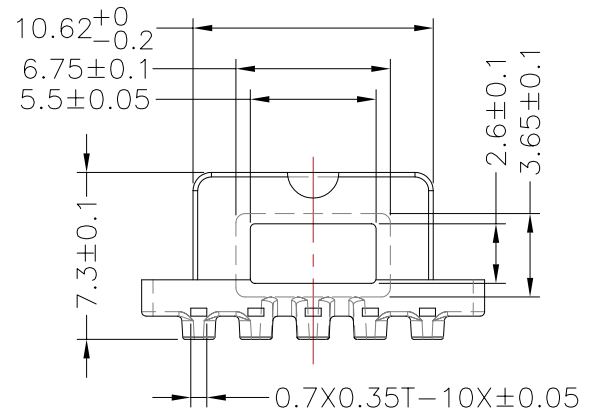
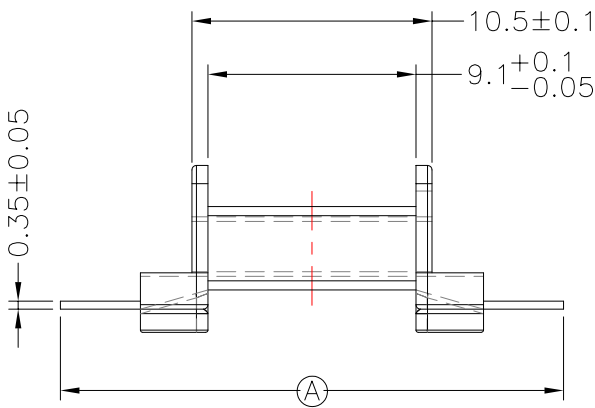
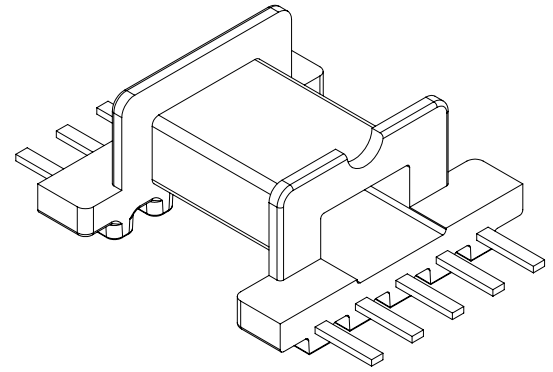
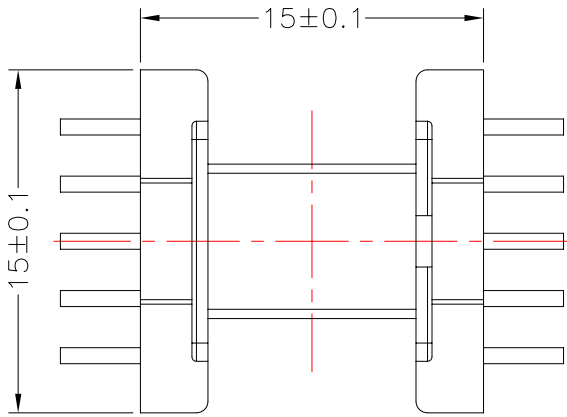

DWG NO.	EFD15-10P-GW-2.5-1B-11				
PART NO.	MATERIAL (BOBBIN)	MATERIAL (TERMINAL)	TERMINAL (PLATING)	PIN ALLOCATION	NOTE
TBI-107-03121.1103	PM-9630	P.B	Sn	ALL PIN (A)=22±0.15	
TBI-107-03121.1113	PM-9630	P.B	Sn	ALL PIN (A)=24±0.15	H
TBI-107-03121.1123	PM-9630	P.B	Sn	ALL PIN (A)=25.5±0.4	
<p>TOLERANCE: .X±0.15 .XX±0.10 .XXX±0.05 UNIT : m/m SCALE 3:1</p>					
Finish:	1. Pb wire Immersion Sn on terminal : Thickness:Sn plating,100,5 μm (200 μ inches) min,Base nickel 0.625 μm (25 μ inches) min. 2. CP wire Immersion Sn on terminal : Thickness:Sn plating,100,5 μm (200 μ inches) min. 3. Coplanarity deviation: 0.10 mm (0.004 inches) max.				REV 1