



**TRANSFORMER BOBBIN
INDUSTRIAL CO.,LTD.**

Tel : 86-769-88789999 Fax : 86-769-88789989
http:// tbi-tw.com e-mail : tb6688@ms46.hinet.net

REVISIONS

REV	SYM	DRAFTER	CHECKER	DATE
①		YAN.TANG	W.H.HSU	08/23/07
②		YAN.TANG	G.F.YANG	11/15/07
③				

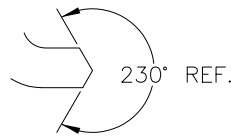
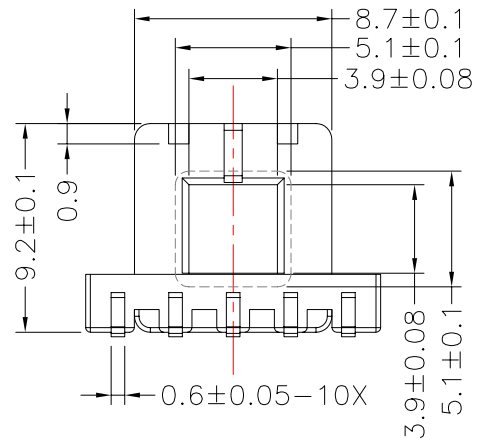
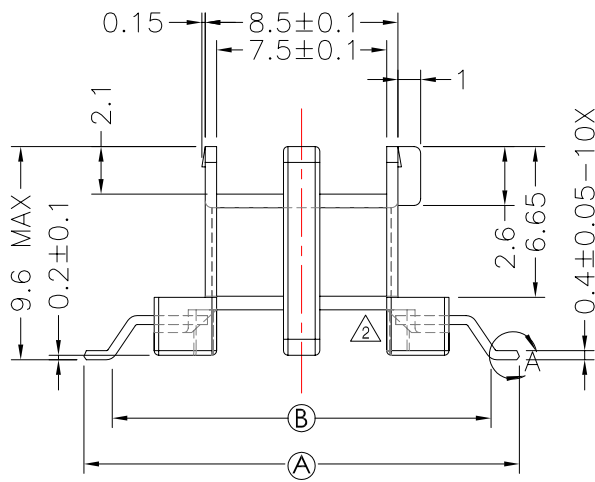
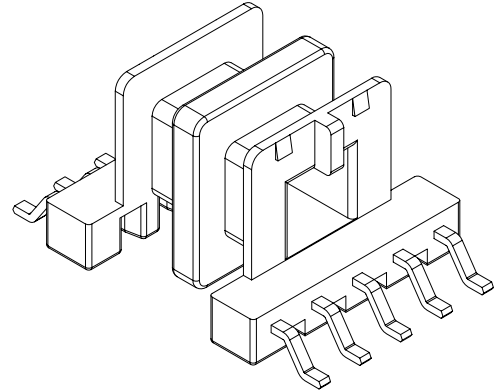
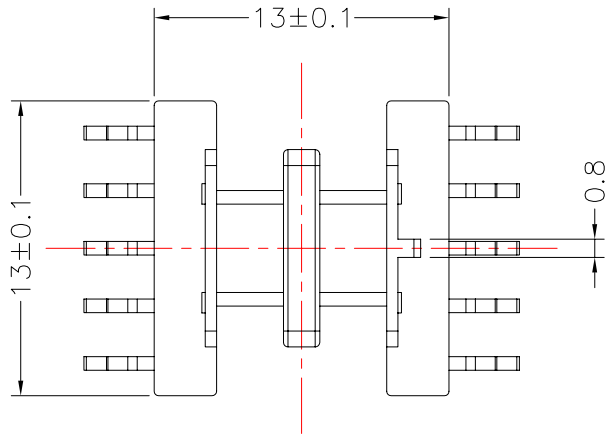

DETAIL:A
PATENTED

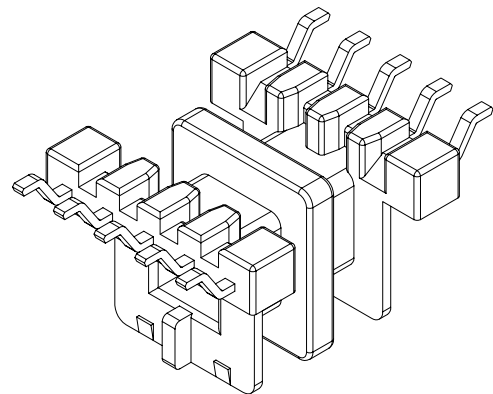
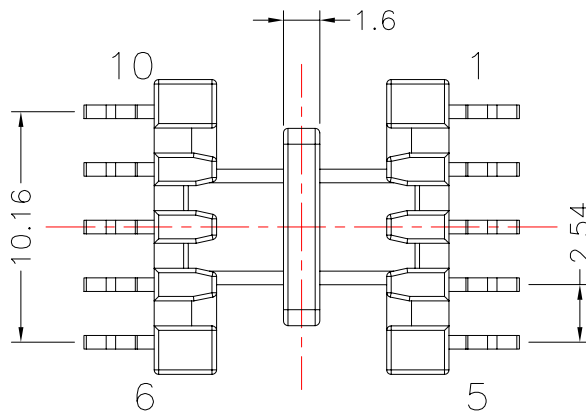

DWG NO. EF12.6-10P-GW-2.54-0G-1-2S

PART NO.	MATERIAL (BOBBIN)	MATERIAL (TERMINAL)	TERMINAL (PLATING)	PIN ALLOCATION	NOTE
TBI-105-01072.103	PM-9630	PB	Sn	ALL PIN;(A)=19.2±0.2;(B)=16.7 Ref.	
TBI-105-01072.113	PM-9630	PB	Sn	ALL PIN;(A)=17.2±0.2;(B)=15.1 Ref.	H
TBI-105-01072.123	PM-9630	PB	Sn	ALL PIN;(A)=17.7±0.15;(B)=15.3 Ref.	
TBI-105-01072.133	PM-9630	PB	Sn	CUT PIN# 2,3,4,7,8,9;(A)=17.2±0.2;(B)=15.1 Ref.	

TOLERANCE: .X±0.15 .XX±0.10 .XXX±0.05 UNIT : m / m SCALE 3 : 1

Finish: 1. PB wire Immersion Sn on terminal : Thickness:Sn plating,100,5 μ m (200 μ inches) min,Base nickel 0.625 μ m (25 μ inches) min.
2. CP wire Immersion Sn on terminal : Thickness:Sn plating,100,5 μ m (200 μ inches) min.
3. Coplanarity deviation: 0.10 mm (0.004 inches) max.

REV 2