



**TRANSFORMER BOBBIN  
INDUSTRIAL CO.,LTD.**

Tel : 86-769-88789999 Fax : 86-769-88789989  
http:// tbi-tw.com e-mail : tb6688@ms46.hinet.net

REVISIONS

REV	SYM	DRAFTER	CHECKER	DATE
2		T.S.LII	W.H.HSU	09/29/04
3		T.S.LII	W.H.HSU	09/30/04
4		T.S.LII	W.H.HSU	07/19/06

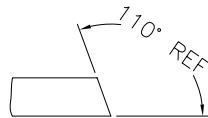
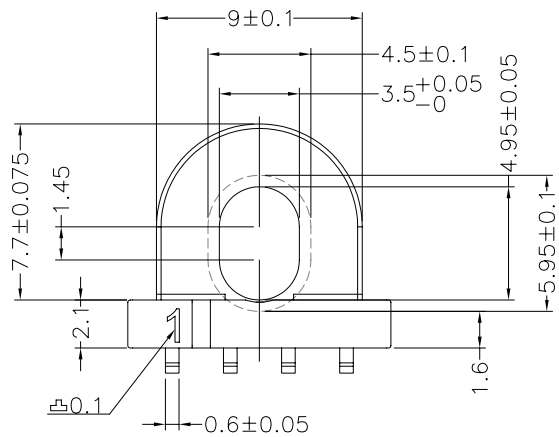
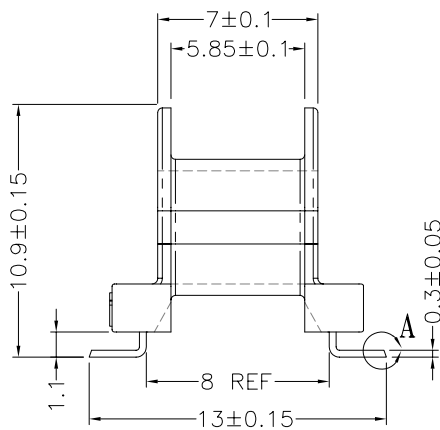
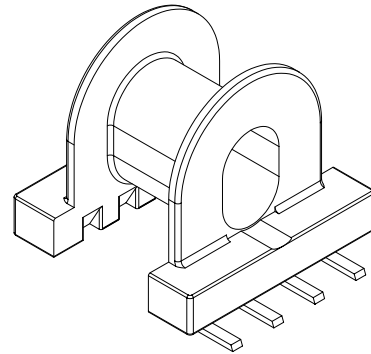
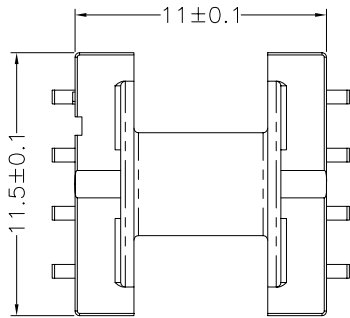

**DETAIL:A-10:1  
PATENTED**

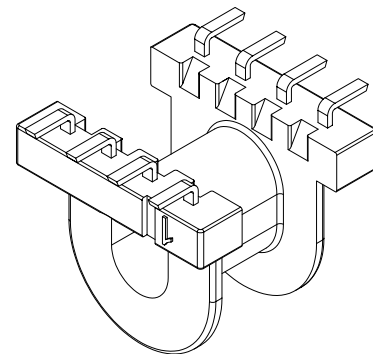
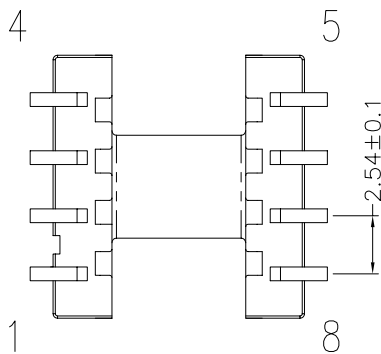

DWG NO. EPX10-8P-L-2.5-A3-1

PART NO.	MATERIAL (BOBBIN)	MATERIAL (TERMINAL)	TERMINAL (PLATING)	PIN ALOCATION	NOTE
----------	-------------------	---------------------	--------------------	---------------	------

3	TBI-103-02131.101	PM-9630	P.B	3 Au	ALL PIN
---	-------------------	---------	-----	------	---------

4	TBI-103-02131.103	PM-9630	P.B	4 Sn	ALL PIN
---	-------------------	---------	-----	------	---------

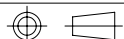

TOLERANCE: .X±0.15 .XX±0.10 .XXX±0.05

UNIT : m / m

SCALE 3 : 1

Finish: 1. Immersion gold on terminal : Thickness gold 0.075 μm (3 μ inches) min, Base nickel 0.625 μm (25 μ inches) min.  
2. Immersion Sn on terminal : Terminal:Sn plating, 100, 5 μm (200 μ inches) min , Base nickel 0.625 μm (25 μ inches) min.  
3. Coplanarity deviation: 0.10 mm (0.004 inches) max.

REV 4