



**TRANSFORMER BOBBIN
INDUSTRIAL CO.,LTD.**

Tel : 886-2-22929999 Fax : 886-2-22925236
http:// tbi-tw.com e-mail : tb6688@ms46.hinet.net

REVISIONS

REV	SYM	DRAFTER	CHECKER	DATE
△		T.S.LII	W.H.HSU	07/21/04
△		T.S.LII	W.H.HSU	12/03/04
△		T.S.LII	W.H.HSU	12/06/04

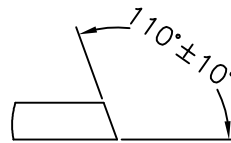
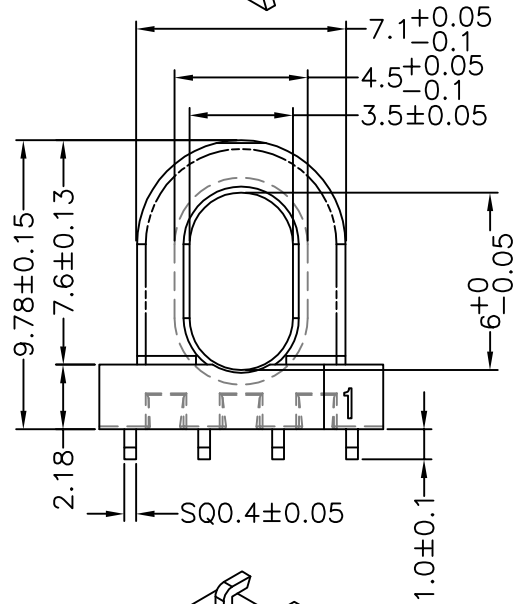
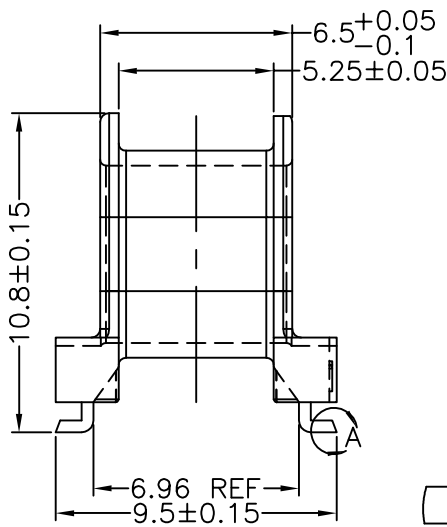
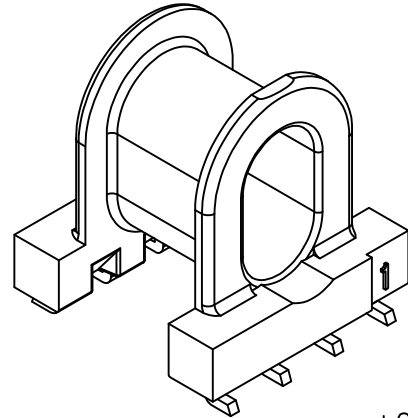
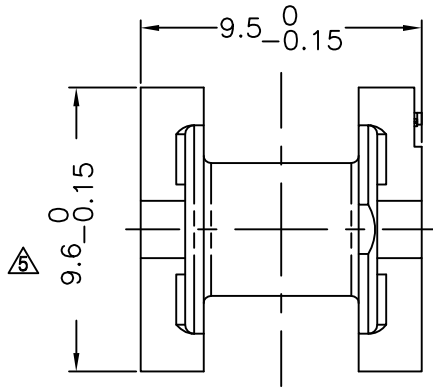

**DETAIL:A
PATENTED**

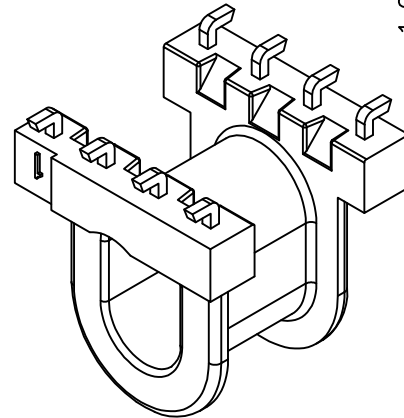
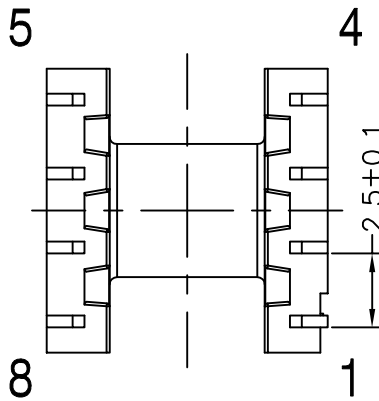

PART NO. EPX9-8P-L-2.5-B-1

DWG NO.	MATERIAL (BOBBIN)	MATERIAL (TERMINAL)	TERMINAL (PLATING)	PIN ALOCATION	BUYER 'S PART NO.
TBI-103-04021.101	PM-9630	P.B	Au	ALL PIN	

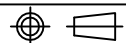

TOLERANCE : .X±0.15 .XX±0.10 .XXX±0.05

UNIT : m/m

SCALE 4 : 1

- Finish:**
1. Immersion gold on terminal : Thickness gold 0.075 μm (3 μ inches) min, Base nickel 0.625 μm (25 μ inches) min.
 2. Immersion Sn on terminal : Terminal: Sn plating, 100, 5 μm (200 μ inches) min , Base nickel 0.625 μm (25 μ inches) min.
 3. Coplanarity deviation: 0.10 mm (0.004 inches)max.

REV 5