

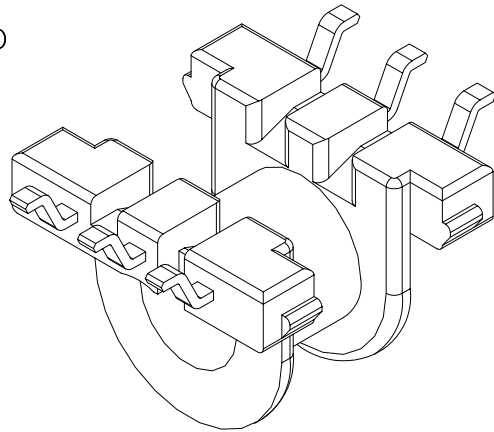

TRANSFORMER BOBBIN INDUSTRIAL CO.,LTD.

Tel : 86-769-88789999 Fax : 86-769-88789989
 http:// tbi-tw.com e-mail : tb6688@ms46.hinet.net

REVISIONS				
REV	SYM	DRAFTER	CHECKER	DATE
△4		Y.G.HSU	W.H.HSU	03/26/07
△5		S.Y.TANG	W.H.HSU	07/11/07
△6		S.Y.TANG	W.H.HSU	09/03/07

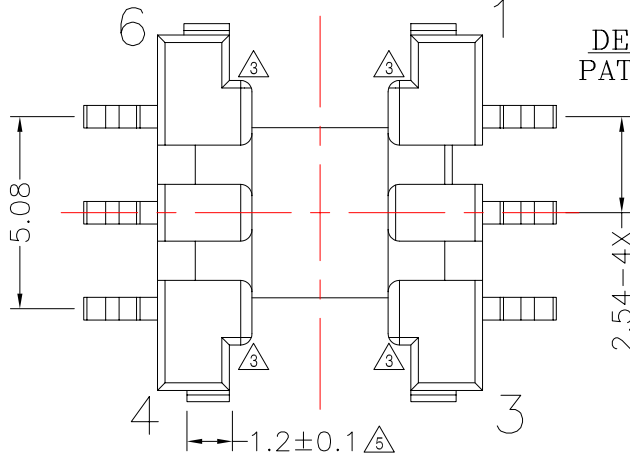
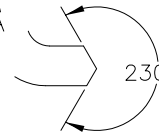
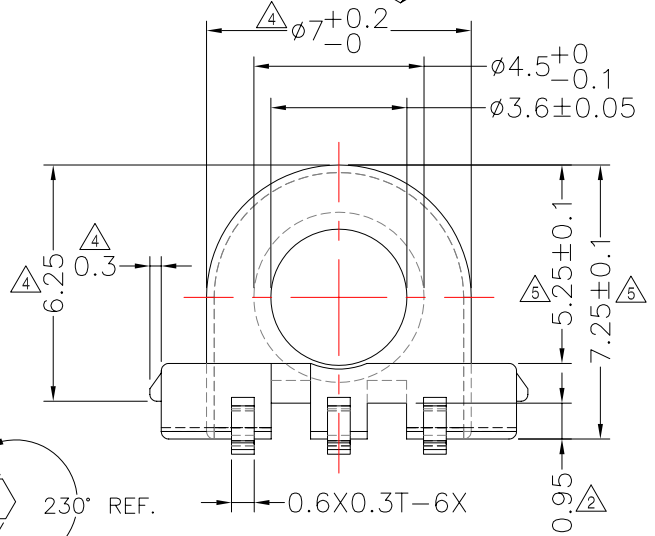
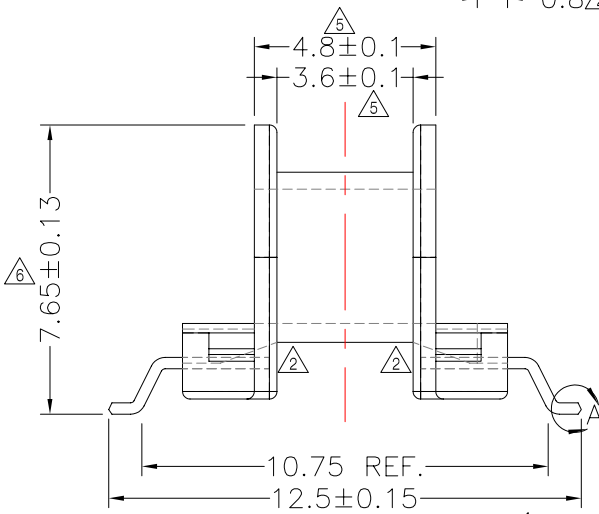
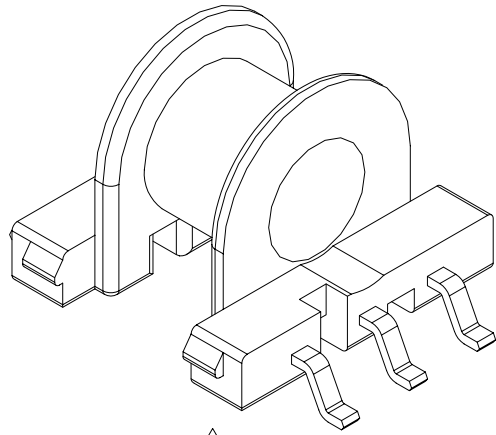
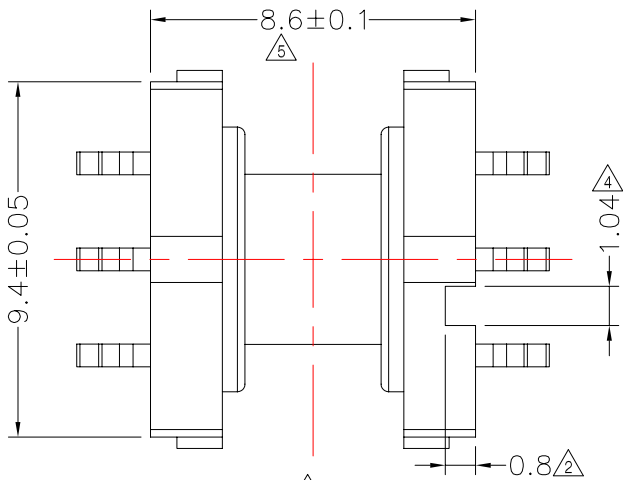

DWG NO.	EP7-6P-GW-2.54-3B-1				
PART NO.	MATERIAL (BOBBIN)	MATERIAL (TERMINAL)	TERMINAL (PLATING)	PIN ALLOCATION	NOTE
TBI-103-08321.103	PM-9630JT	P.B	Sn	ALL PIN	

TOLERANCE: .X±0.15 .XX±0.10 .XXX±0.05 UNIT : m / m SCALE 5 : 1

Finish: 1. Pb wire Immersion Sn on terminal : Thickness:Sn plating,100,5 μm (200 μ inches) min,Base nickel 0.625 μm (25 μ inches) min.
 2. CP wire Immersion Sn on terminal : Thickness:Sn plating,100,5 μm (200 μ inches) min.
 3. Coplanarity deviation: 0.10 mm (0.004 inches) max.

REV 6