



**TRANSFORMER BOBBIN
INDUSTRIAL CO.,LTD.**

Tel : 886-2-22929999 Fax : 886-2-22925236
 http:// tbi-tw.com e-mail : tb6688@ms46.hinet.net

REVISIONS

REV	SYM	DRAFTER	CHECKER	DATE
△		T.S.LII	W.H.HSU	08/21/03
△		T.S.LII	W.H.HSU	09/01/03
△		T.S.LII	W.H.HSU	02/17/05

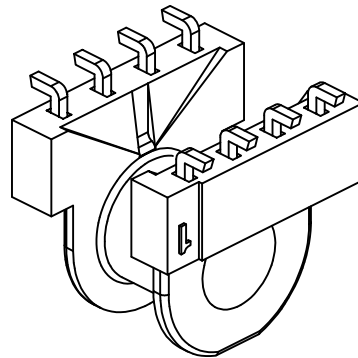
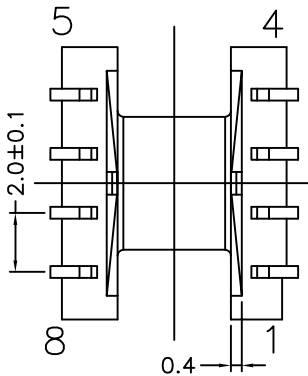
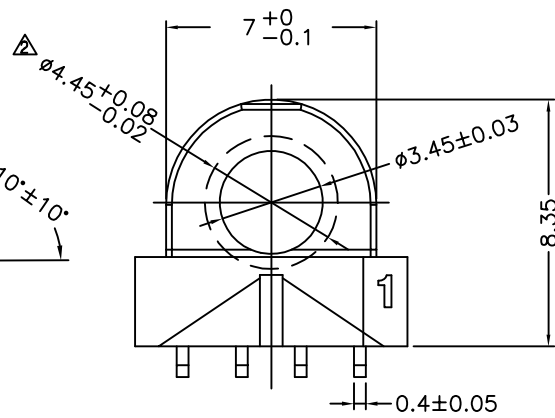
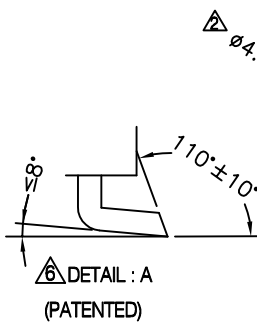
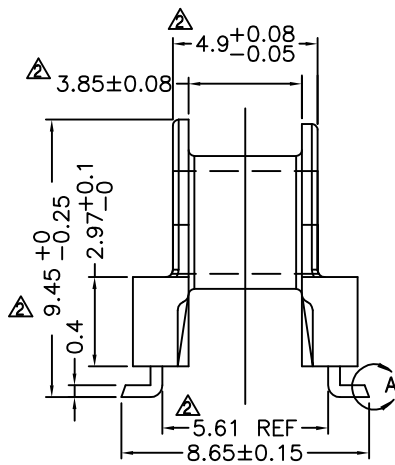
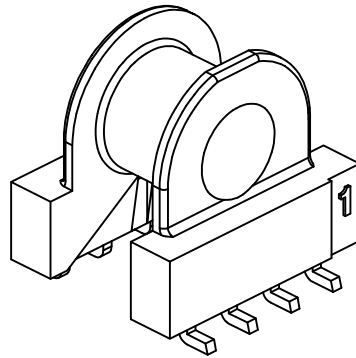
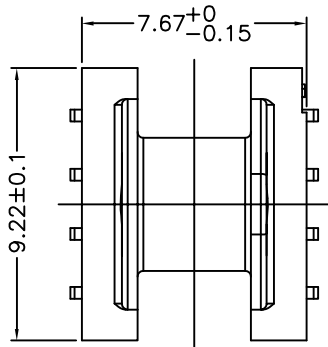

PART NO.	EP7-8P-L-2.0V-A8-1				
DWG NO.	MATERIAL (BOBBIN)	MATERIAL (TERMINAL)	TERMINAL (PLATING)	PIN ALOCATION	BUYER 'S PART NO.
TBI-103-08181.101	PM-9630	P.B	Au	ALL PIN	

	TOLERANCE: .X±0.15 .XX±0.10 .XXX±0.05	UNIT : m/m	SCALE X : 1
--	---------------------------------------	------------	-------------

Finish:	1. Immersion gold on terminal : Thickness gold 0.075 μm (3 μ inches) min, Base nickel 0.625 μm (25 μ inches) min. 2. Immersion Sn on terminal : Terminal: Sn plating, 100, 5 μm (200 μ inches) min , Base nickel 0.625 μm (25 μ inches) min. 3. Coplanarity deviation: 0.10 mm (0.004 inches)max.	REV	9
---------	--	-----	---