

**TBI** TRANSFORMER BOBBIN INDUSTRIAL CO.,LTD.

Phone 886-2-22929999 Fax 886-2-22925236  
E-MAIL: tb6688@ms46.hinet.net

REVISIONS

REV	SYM	DRAFTER	CHECKER	DATE
△		T.S.LII	W.H.HSU	02/07/02
△		T.S.LII	W.H.HSU	02/08/02
△		T.S.LII	W.H.HSU	11/29/02

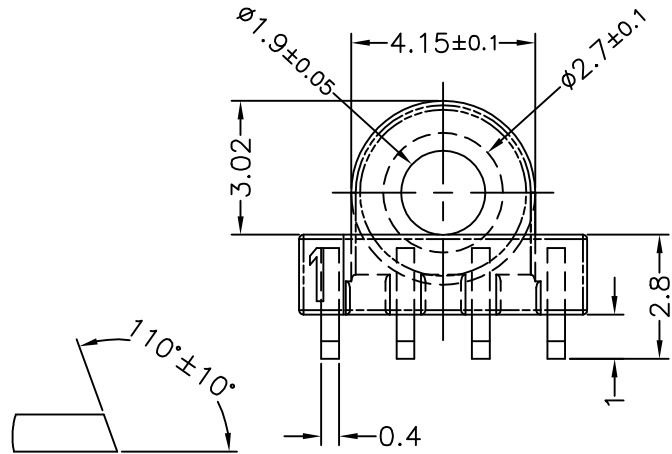
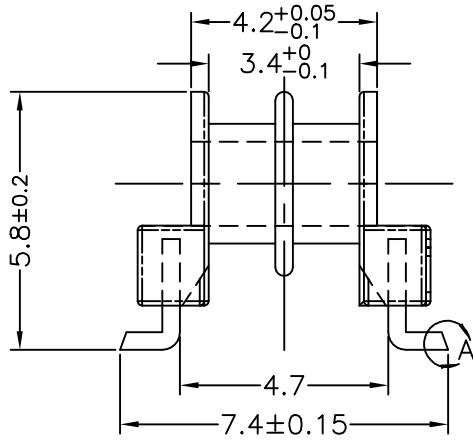
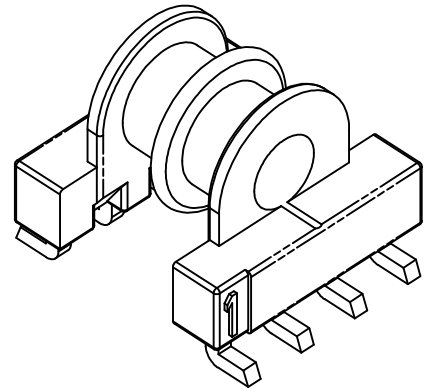
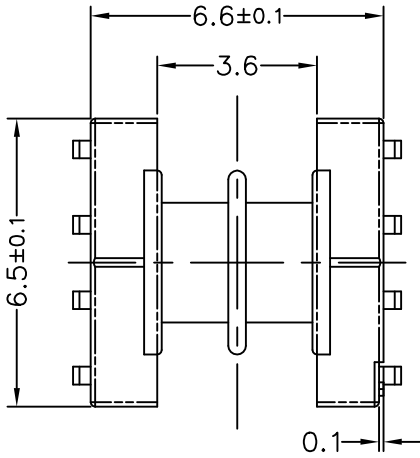

DETAIL:A-10:1  
PATENTED

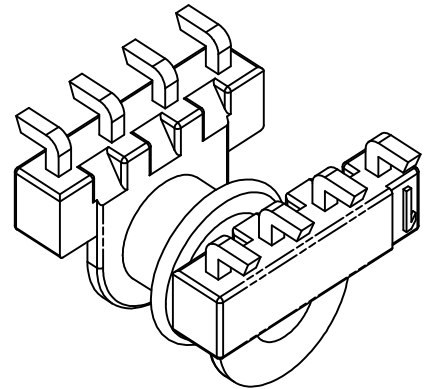
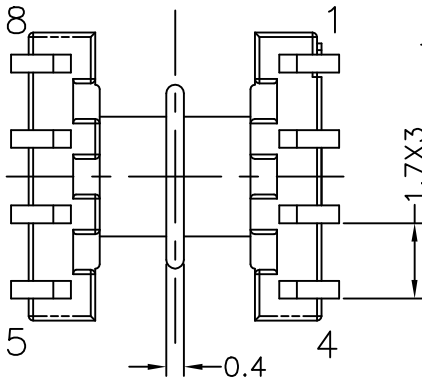

PART NO.	EP6-8P-L-1.7-C-1-2S						
DWG NO.	TBI-103-07032.1XX						
TBI NO.	MATERIAL (BOBBIN)	MATERIAL (TERMINAL)	TERMINAL (PLATING)		.103	ALL PIN+Sn	
					.102	ALL PIN+Sn/Pb	
					.101	ALL PIN+Au	
103-07032.1XX	PM-9630	CP WIRE		PART NO.	REV	MODE NO	PIN LOCATION
				Finish:			TOLERANCE
				1. Immersion gold on terminal.			X±
				Thickness gold 0.075 μm (3 μ inches) min,			X X±
				Base nickel 0.625 μm (25 μ inches) min.			UNIT
				2. Coplanarity deviation: 0.004 inches max.			m/m
							SCALE
							6 : 1
							REV
							3