

TBI TRANSFORMER BOBBIN INDUSTRIAL CO.,LTD.

Phone 886-2-22929999 Fax 886-2-22925236
E-MAIL: tb6688@ms46.hinet.net

REVISIONS

| REV | SYM | DRAFTER | CHECKER | DATE |
|-----|-----|---------|---------|----------|
| △ | | T.S.LII | W.H.HSU | 02/07/02 |
| △ | | T.S.LII | W.H.HSU | 02/08/02 |
| △ | | T.S.LII | W.H.HSU | 11/29/02 |

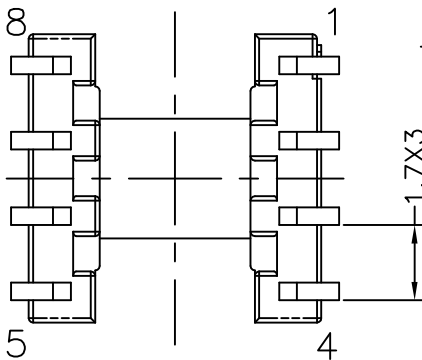
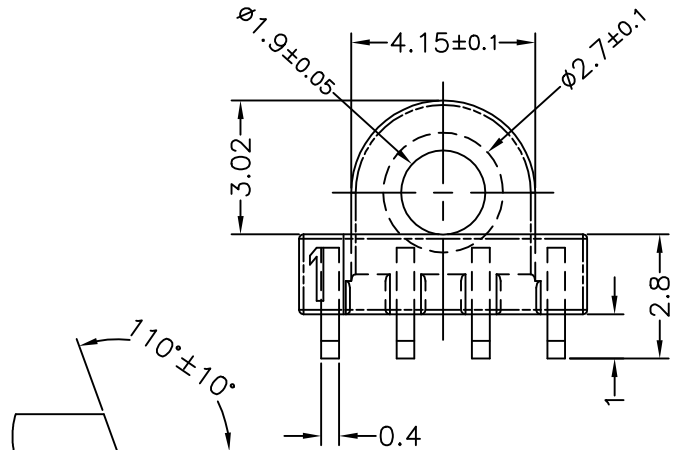
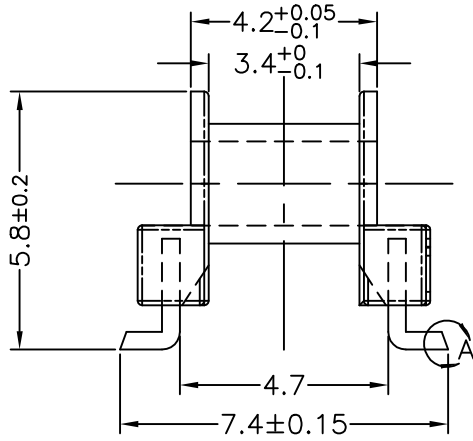
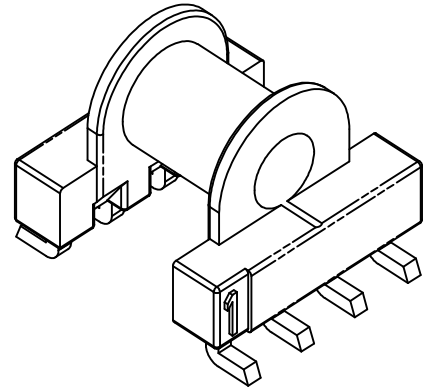
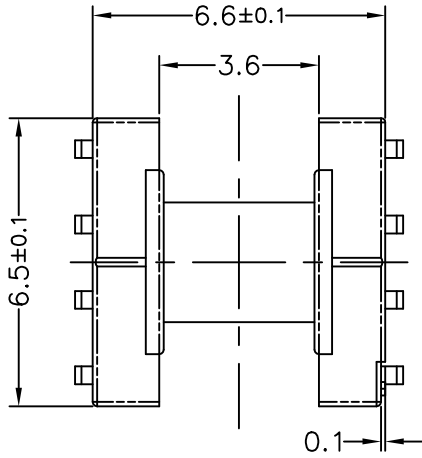

DETAIL:A-10:1
PATENTED

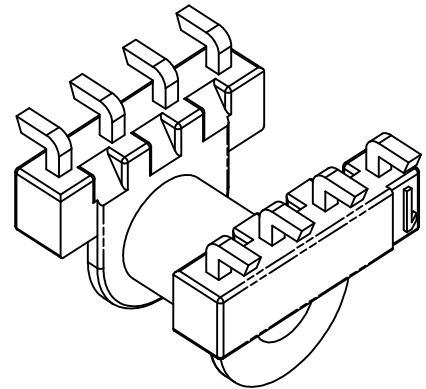

| | | | | | | | |
|---------------|-------------------|---------------------|--------------------|---|------|---------------|--------------|
| PART NO. | EP6-8P-L-1.7-C-1 | | | | | | |
| DWG NO. | TBI-103-07031.1XX | | | | | | |
| TBI NO. | MATERIAL (BOBBIN) | MATERIAL (TERMINAL) | TERMINAL (PLATING) | | .103 | ALL PIN+Sn | |
| | | | | | .102 | ALL PIN+Sn/Pb | |
| | | | | | .101 | ALL PIN+Au | |
| 103-07031.1XX | PM-9630 | CP WIRE | | PART NO. | REV | MODE NO | PIN LOCATION |
| | | | | Finish: | | | TOLERANCE |
| | | | | 1. Immersion gold on terminal. | | | X± XX± |
| | | | | Thickness gold 0.075 μm (3 μ inches) min, | | | UNIT |
| | | | | Base nickel 0.625 μm (25 μ inches) min. | | | m/m |
| | | | | 2. Coplanarity deviation: 0.004 inches max. | | | SCALE |
| | | | | | | | 6 : 1 |
| | | | | | | | REV |
| | | | | | | | 3 |