



TRANSFORMER BOBBIN INDUSTRIAL CO.,LTD.

Tel : 86-769-88789999 Fax : 86-769-88789989
http:// tbi-tw.com e-mail : tb6688@ms46.hinet.net

REVISIONS

REV	SYM	DRAFTER	CHECKER	DATE
1		X.H.GU	G.F.YANG	03/11/14
2				
3				

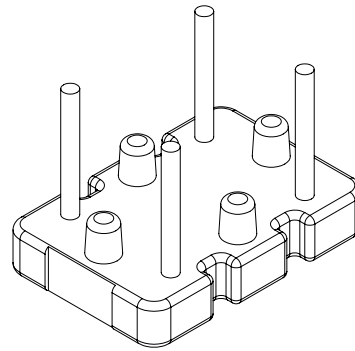
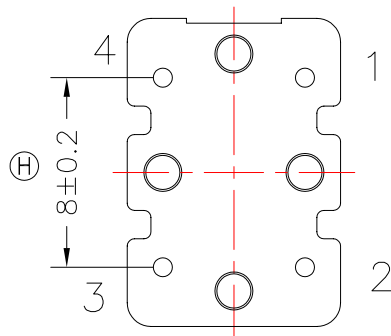
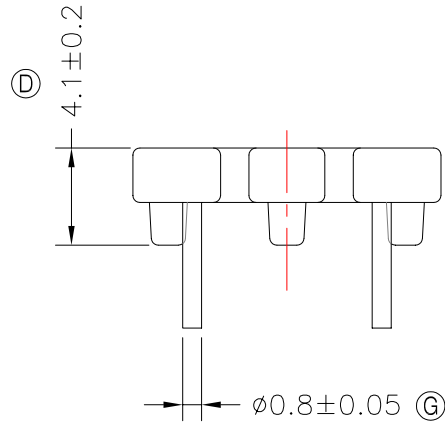
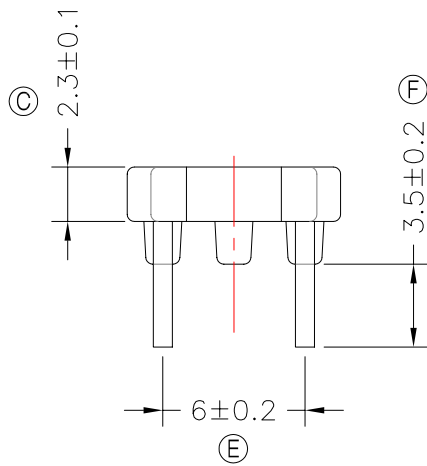
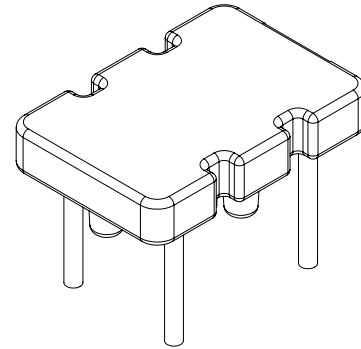
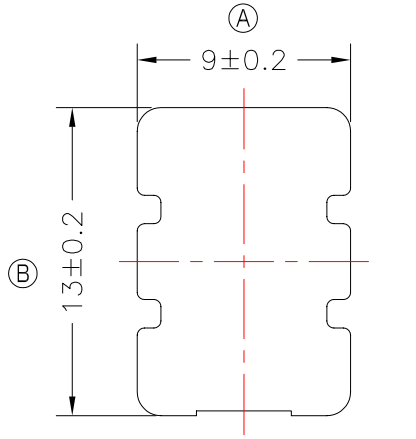

DWG NO.	B13X9-4P-TH-C7-12				
PART NO.	MATERIAL (BOBBIN)	MATERIAL (TERMINAL)	TERMINAL (PLATING)	PIN ALLOCATION	NOTE
TBI-220-16371.1206	PM-9820	CP WIRE	Sn	ALL PIN	S
	TOLERANCE:0<L<=4:±0.1 4<L<=16:±0.2 16<L<=63:±0.3			UNIT : m / m	SCALE 1 : 1
Finish:	1. PB wire Immersion Sn on terminal : Thickness:Sn plating,100%,5 μm (200 μ inches) min,Base nickel 0.625 μm (25 μ inches) min. 2. CP wire Immersion Sn on terminal : Thickness:Sn plating,100%,5 μm (200 μ inches) min. 3. Coplanarity deviation: 0.10 mm (0.004 inches) max.				
	REV				1