



TRANSFORMER BOBBIN
INDUSTRIAL CO.,LTD.

Tel : 86-769-88789999 Fax : 86-769-88789989
http:// tbi-tw.com e-mail : tb6688@ms46.hinet.net

REVISIONS

REV	SYM	DRAFTER	CHECKER	DATE
①		F.LU	G.F.YANG	02/18/12
②				
③				

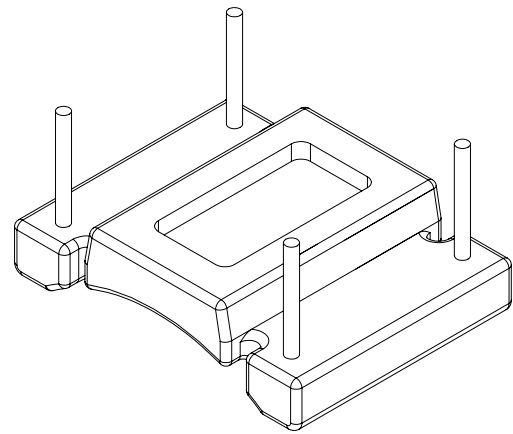
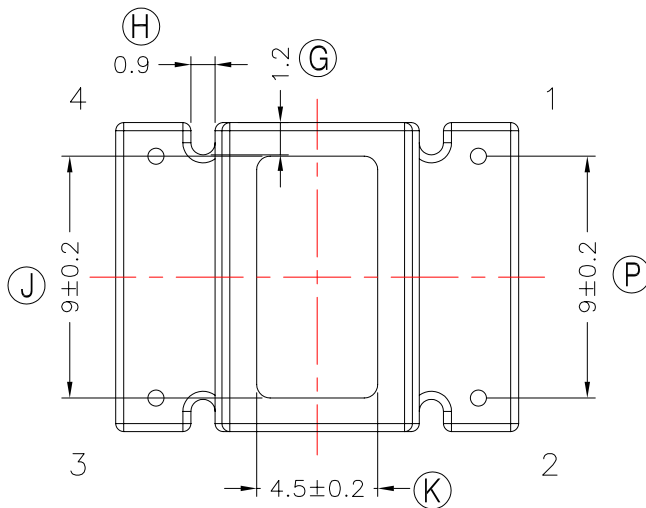
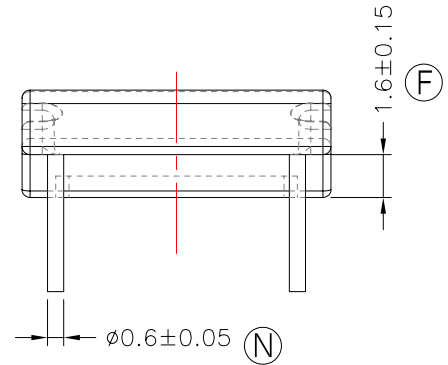
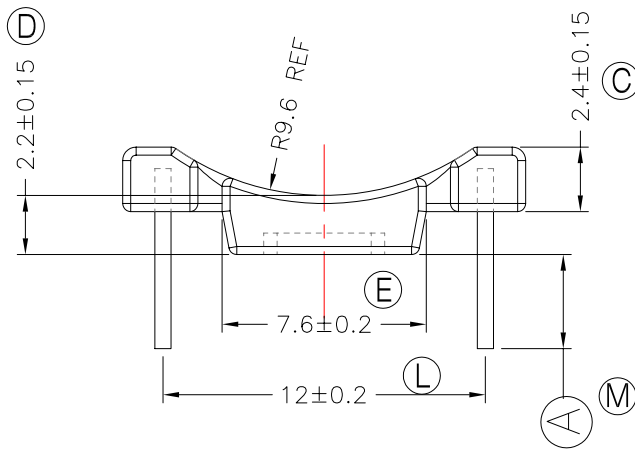
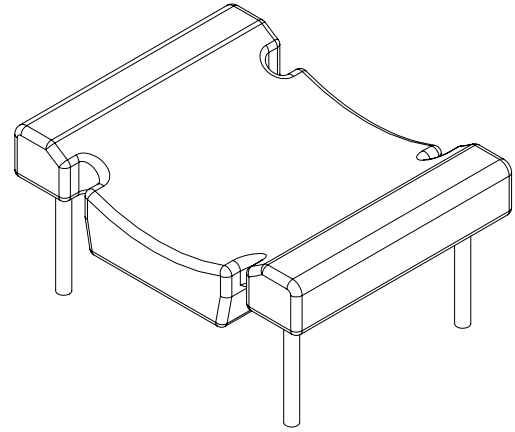
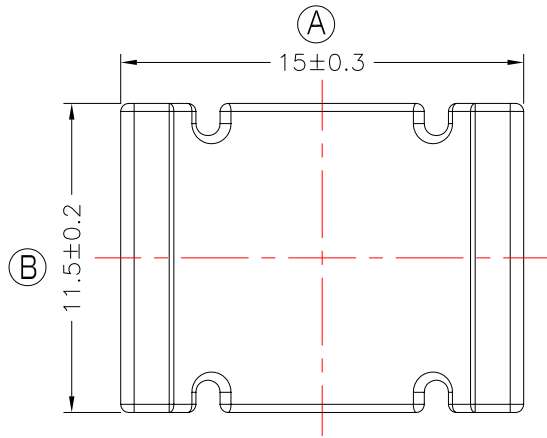

NOTE: 1. 焊錫前拉力:1.0KG MIN; 焊錫後拉力:1.5KG MIN
2. 強度須1.5kg MIN

DWG NO. B15X12-4P-TH-C4-12

PART NO.	MATERIAL (BOBBIN)	MATERIAL (TERMINAL)	TERMINAL (PLATING)	PIN ALLOCATION	NOTE
TBI-220-16341.1206	PM-9820	CP WIRE	Sn	ALL PIN (A) = 3.5±0.2	S
TBI-220-16341.1216	PM-9820	CP WIRE	Sn	ALL PIN (A) = 2.8±0.3	H
TBI-220-16341.1226	PM-9820	CP WIRE	Sn	ALL PIN (A) = 2.8±0.3	咬花外露:咬花寬度1.5±0.3, 深度0.05+0.02/-0.03

TOLERANCE: 0<L<=4:±0.1 4<L<=16:±0.2 16<L<=63:±0.3 pin pitch:±0.2 UNIT : m / m SCALE 1 : 1

Finish: 1. PB wire Immersion Sn on terminal : Thickness:Sn plating,100,5 μm (200 μ inches) min,Base nickel 0.625 μm (25 μ inches) min.
2. CP wire Immersion Sn on terminal : Thickness:Sn plating,100,5 μm (200 μ inches) min.
3. Coplanarity deviation: 0.10 mm (0.004 inches) max.

REV 1